



PETERSEN  
STAINLESS RIGGING



STAINLESS STEEL SHACKLES, LIFTING POINTS  
& COMPONENTS FOR LIFTING APPLICATIONS

# CONTENTS

## SHACKLES

17/4PH High Tensile Stainless Steel D & Bow Shackles	4
Marine Grade 316L High Corrosion Resistance Stainless Steel WLL Screw Pin D & Bow Shackles	5
Marine Grade 316L High Corrosion Resistance Stainless Steel D & Bow Shackles with Safety Pin	6
Marine Grade 316L High Corrosion Resistance Stainless Steel Chain Link D Shackles	7
NSN Low Magnetic Permeability Stainless Steel D & Bow Shackles	8
Duplex and Super Duplex WLL Screw Pin D & Bow Shackles	9
Black Finish 17/4PH High Tensile Stainless Steel D & Bow Shackles	10

## LIFTING POINTS

Stainless Steel Swing Bolts / Eye Bolts to DIN 444 Type A and Type B	11
Stainless Steel DIN 580:201 Eye Bolts & DIN 585:2010 Eye Nuts	12-13
Stainless Steel Centre Swivel Lifting Points	14
Stainless Steel U Bolts	15

## TURNBUCKLES

High Corrosion Resistance Tested Turnbuckles - Jaw/Jaw	18
High Corrosion Resistance Tested Turnbuckles - Jaw/Eye	19
High Corrosion Resistance Tested Turnbuckles - Eye/Eye	19

## WIRE ROPE

Stainless Steel Wire Ropes (AISI 316)	18
Stainless Steel Thimbles	19
Stainless Steel Wire Rope Clips (Bulldog Grips) to DIN 741	19

## EN SWAGING FOR LIFTING - TO EN 13411-8

EN Swaging for Lifting - the Petersen Swaging System	20-21
EN Stainless Steel Swage Studs	22
EN Stainless Steel Swage Eyes	23
EN Stainless Steel Shackle Toggles	23
EN Stainless Steel Swage Forks	24

## MISCELLANEOUS

Blaydon Blocks (Industrial Lifting Blocks)	25
--	----

## INFORMATION

Certification	26
Terms & Conditions	27
Contact Us	28

NOT EVERYTHING IN OUR LIFTING RANGE IS IN THIS CATALOGUE.

IF YOU CAN'T SEE A PRODUCT, SPEAK TO OUR EXPERT TEAM - WE'D BE HAPPY TO HELP!

---

WE ALSO DO PRODUCTS FOR MARINE AND ARCHITECTURAL APPLICATIONS; SEE OUR WEBSITE FOR MORE INFORMATION.

# ABOUT US

PETERSEN HAS BEEN MANUFACTURING SHACKLES FOR OVER 100 YEARS.

BY SPECIALISING IN THE TURNING, UPSETTING AND FORMING OF STAINLESS STEEL BAR, WE DEVELOPED THE EXPERTISE TO MANUFACTURE LOAD TESTED STAINLESS STEEL SHACKLES, TURNBUCKLES AND WIRE ROPE TERMINATIONS.

OUR MANUFACTURING BASE IS IN THE UK AND OUR FULL RANGE IS PRODUCED FROM EUROPEAN MATERIALS, MEANING WE CAN PROVIDE FULL TRACEABILITY FROM MILL TO FINAL APPLICATION.

## RIGOROUSLY SELECTED MATERIALS SPECIALLY MANUFACTURED

Not all stainless steels are created equal, and we work closely with our European suppliers to ensure our raw materials are of the highest quality and fully traceable.

We then use specialist manufacturing methods to ensure the structural integrity of the material is preserved. No welding or casting is involved; instead, we turn, upset forge and form the solid stainless steel bar, giving you the best possible corrosion resistance and fatigue strength every time.

## EVERY ITEM TESTED AND CERTIFIED

Each and every lifting shackle is individually tested before it comes to you. The test involves loading the lifting shackle to its proof load, which is always twice the working load limit (safe working load). Our minimum breaking loads are 6 times the WLL but in testing we regularly see shackles getting to 8 or 10 times the WLL before failure.

Once testing is complete, a test certificate is produced detailing the relevant product and test information, including the identification number, date of manufacture, product code and description, date of test, applied load and traceability number.

We can also provide you with material certificates and a declaration of conformity on request – even after the goods have shipped!

All of our CE marked products are also supplied with safe usage instructions.



*Each lifting shackle is individually etched*

## A TEAM FOCUSED ON SOLUTIONS

From custom designed products to meet your exact requirements through to additional quality measures such as the sequential marking of items or use of your in-house reference numbers, our design and production team is focused on finding solutions to the problems you face. Speak to our expert team to find out how our fast and flexible approach to design and manufacture can help you.

## EXCEPTIONAL QUALITY AS STANDARD

Every item that leaves our UK manufacturing base is assured by our ISO 9001 certified quality system, and we provide full traceability and certification from steel mill to site as standard. The scope of our approval covers the design and manufacture of stainless steel lifting equipment, cable termination and tensioning equipment and ancillary components for the marine, oil and gas, offshore, construction and defence industries.

We are committed to providing our customers with products they can trust to perform, every single time.

# 17/4PH HIGH TENSILE STAINLESS STEEL D & BOW SHACKLES

## PRODUCT FEATURES

Manufactured from 17/4PH precipitation hardening martensitic stainless steel with a corrosion resistance similar to 18/8 grade steels

Excellent for general lifting applications - high tensile properties while avoiding work hardening

Factor of Safety 6:1

Manufactured using the latest technology in electrical upset forging

Available with 4 pin types - standard screw collar pin (A Type), extended screw collar pin (AL Type), countersunk head (B Type), safety pin (E Type)

All shackles CE marked and supplied with instruction leaflet on safe use and storage



TYPE A

TYPE AL

TYPE B

TYPE E



TYPE A

TYPE AL

TYPE B

TYPE E

## QUALITY FEATURES

Proof load tested to 2 x WLL and certified at our UK manufacturing facility

Manufactured in accordance with the Machine Directive 2006/42/EC

Inspection certificate BS EN 10204 3.1 provided as standard

High quality finish and excellent polish

## TYPICAL APPLICATIONS

General lifting, including in off-shore applications

General lifting and tethering in leisure marine applications - not submerged

High strength makes it suitable for lifting in aerospace and other high-tech industries

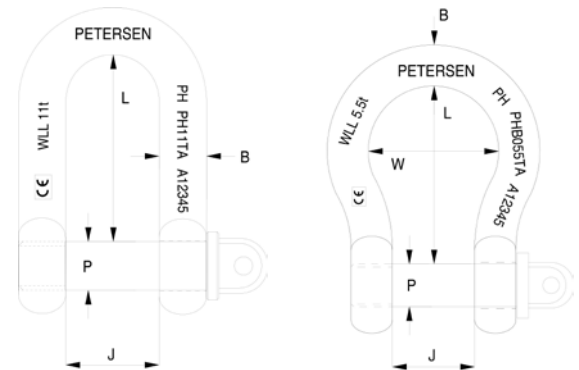

## D SHACKLES

DIMENSIONS (MM) & WLL					PIN STYLES & ITEM CODES					NOMINAL WEIGHT Per Shackle (kg)
WLL (kg)	Pin Dia (P)	Body Dia (B)	Jaw Gap (J)	Length (L)	A Type Pin	AL Type Pin	B Type Pin	E Type Pin	E Type Pin with Nylok	
1000	9.5	8.0	16.0	32.0	PH1TA	PH1TAL	PH1TB	PH1TE	PH1TE-NY	0.09
2000	12.7	10.0	20.0	40.0	PH2TA	PH2TAL	PH2TB	PH2TE	PH2TE-NY	0.15
3000	16.0	12.7	25.0	50.0	PH3TA	PH3TAL	PH3TB	PH3TE	PH3TE-NY	0.35
5000	19.0	16.0	32.0	64.0	PH5TA	PH5TAL	PH5TB	PH5TE	PH5TE-NY	0.55
7000	22.2	19.0	38.0	76.0	PH7TA	PH7TAL	PH7TB	PH7TE	PH7TE-NY	1.00
9000	25.4	22.2	44.0	88.0	PH9TA	PH9TAL	PH9TB	PH9TE	PH9TE-NY	1.90
11000	28.6	25.4	51.0	102.0	PH11TA	PH11TAL	PH11TB	PH11TE	PH11TE-NY	2.90
13000	31.8	28.6	57.0	114.0	PH13TA	PH13TAL	PH13TB	PH13TE	PH13TE-NY	3.10
15000	34.9	31.8	64.0	128.0	PH15TA	PH15TAL	PH15TB	PH15TE	PH15TE-NY	4.35
18000	38.0	34.9	76.0	152.0	PH18TA	PH18TAL	PH18TB	PH18TE	PH18TE-NY	5.30

## BOW SHACKLES

DIMENSIONS (MM) & WLL						PIN STYLES & ITEM CODES					NOMINAL WEIGHT Per Shackle (kg)
WLL (kg)	Pin Dia (P)	Body Dia (B)	Jaw Gap (J)	Inside Bow (W)	Length (L)	A Type Pin	AL Type Pin	B Type Pin	E Type Pin	E Type Pin with Nylok	
800	9.5	8.0	16.0	24.0	32.0	PHB008TA	PHB008TAL	PHB008TB	PHB008TE	PHB008TE-NY	0.09
1500	12.7	10.0	20.0	30.0	40.0	PHB015TA	PHB015TAL	PHB015TB	PHB015TE	PHB015TE-NY	0.16
2500	16.0	12.7	25.0	38.0	50.0	PHB025TA	PHB025TAL	PHB025TB	PHB025TE	PHB025TE-NY	0.37
4000	19.0	16.0	32.0	48.0	64.0	PHB040TA	PHB040TAL	PHB040TB	PHB040TE	PHB040TE-NY	0.58
5500	22.2	19.0	38.0	57.0	76.0	PHB055TA	PHB055TAL	PHB055TB	PHB055TE	PHB055TE-NY	1.05
7500	25.4	22.2	44.0	66.0	88.0	PHB075TA	PHB075TAL	PHB075TB	PHB075TE	PHB075TE-NY	1.99
9000	28.6	25.4	51.0	76.0	102.0	PHB090TA	PHB090TAL	PHB090TB	PHB090TE	PHB090TE-NY	3.05
11000	31.8	28.6	57.0	86.0	114.0	PHB110TA	PHB110TAL	PHB110TB	PHB110TE	PHB110TE-NY	3.26
13000	34.9	31.8	64.0	95.0	128.0	PHB130TA	PHB130TAL	PHB130TB	PHB130TE	PHB130TE-NY	4.57
15000	38.0	34.9	76.0	105.0	140.0	PHB150TA	PHB150TAL	PHB150TB	PHB150TE	PHB150TE-NY	5.57

# MARINE GRADE 316L WLL SCREW PIN D & BOW SHACKLES

## PRODUCT FEATURES

Manufactured from low carbon stainless steel EN10088 1.4404 (Marine Grade 316L), which corresponds to UNS S31603, and 316S11

Meets the performance requirements of EN 13889:2003 and US Federal Specification RR-C-271 Type IVA (Anchor Shackles) and Type IVB (Chain Shackles), Classes 2 (Screw Pin) and 3 (Bolt, Nut and Cotter), Grade A

Manufactured using the latest technology in electrical upset forging

Factor of Safety 6:1

Available with 2 pin types - Standard screw collar pin (A Type) and countersunk head (B Type)

All shackles CE marked and supplied with instruction leaflet on safe use and storage

Inspection certificate BS EN 10204 3.1 provided as standard

High quality finish and excellent polish

## TYPICAL APPLICATIONS

General lifting, including in off-shore applications, where a high level of corrosion resistance is required

Water utility installations and other corrosive facilities, including chemical installations, chlorine plants, etc.

Pump chains and pump lifting

General lifting and tethering in leisure marine applications

## QUALITY FEATURES

Proof load tested to 2 x WLL and certified at our UK manufacturing facility

Manufactured in accordance with the Machine Directive 2006/42/EC



TYPE A

TYPE B

TYPE A

TYPE B

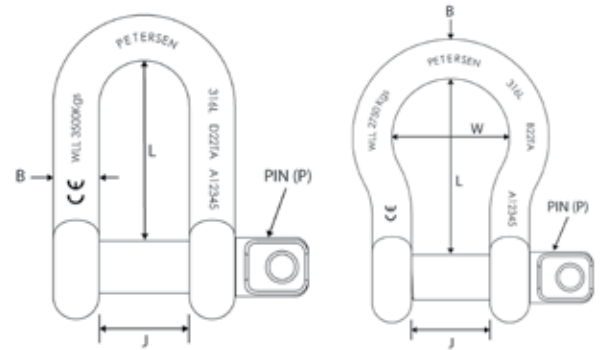

## D SHACKLES

DIMENSIONS (MM) & WLL					PIN STYLES & ITEM CODES		NOMINAL WEIGHT Per Shackle (kg)
WLL (kg)	Pin Dia (P)	Body Dia (B)	Jaw Gap (J)	Length (L)	A Type Pin	B Type Pin	
130	4.0	4.0	8.0	16.0	D04TA	D04TB	0.01
200	5.0	5.0	10.0	20.0	D05TA	D05TB	0.01
325	6.0	6.0	13.0	25.0	D06TA	D06TB	0.02
500	8.0	8.0	16.0	32.0	D08TA	D08TB	0.05
800	9.5	9.5	19.0	38.0	D10TA	D10TB	0.10
1000	11.0	11.0	22.0	44.0	D11TA	D11TB	0.15
1250	12.7	12.7	26.0	52.0	D12TA	D12TB	0.24
1660	16.0	14.3	29.0	58.0	D16TA	D16TB	0.45
2330	19.0	16.0	32.0	64.0	D19TA	D19TB	0.59
3500	22.2	19.0	38.0	76.0	D22TA	D22TB	1.00
4500	25.4	22.2	44.0	88.0	D25TA	D25TB	1.90
5500	28.6	25.4	51.0	102.0	D28TA	D28TB	2.90
6500	31.8	28.6	57.0	114.0	D32TA	D32TB	3.10
7500	34.9	31.8	64.0	128.0	D35TA	D35TB	4.35
9000	38.0	34.9	70.0	140.0	D38TA	D38TB	5.30
12000	42.0	38.1	76	152.0	D42TA	D42TB	6.99
18000	50.0	44.5	90	180.0	D50TA	D50TB	10.90

## BOW SHACKLES

DIMENSIONS (MM) & WLL						PIN STYLES & ITEM CODES		NOMINAL WEIGHT Per Shackle (kg)
WLL (kg)	Pin Dia (P)	Body Dia (B)	Jaw Gap (J)	Inside Bow (W)	Length (L)	A Type Pin	B Type Pin	
130	4.0	4.0	8.0	12.0	16.0	B04TA	B04TB	0.01
200	5.0	5.0	10.0	16.0	22.0	B05TA	B05TB	0.01
260	6.0	6.0	13.0	19.0	28.0	B06TA	B06TB	0.03
400	8.0	8.0	16.0	25.0	35.0	B08TA	B08TB	0.06
630	9.5	9.5	19.0	28.0	38.0	B10TA	B10TB	0.11
800	11.0	11.0	22.0	33.0	46.0	B11TA	B11TB	0.16
1000	12.7	12.7	26.0	38.0	52.0	B12TA	B12TB	0.27
1330	16.0	14.3	29.0	43.0	60.0	B16TA	B16TB	0.50
2000	19.0	16.0	32.0	50.0	68.0	B19TA	B19TB	0.63
2750	22.2	19.0	38.0	57.0	76.0	B22TA	B22TB	1.05
3750	25.4	22.2	44.0	66.0	88.0	B25TA	B25TB	1.99
4500	28.6	25.4	51.0	76.0	102.0	B28TA	B25TB	3.05
5500	31.8	28.6	57.0	86.0	114.0	B32TA	B32TB	3.26
6500	34.9	31.8	64.0	95.0	128.0	B35TA	B35TB	4.57
7500	38.0	34.9	70.0	105.0	140.0	B38TA	B38TB	5.57
10000	42.0	38.1	76	114.0	152.0	B42TA	B42TB	7.35
15000	50.0	44.5	90	135.0	180.0	B50TA	B50TB	11.20

# MARINE GRADE 316L HIGH CORROSION RESISTANCE STAINLESS STEEL D & BOW SHACKLES WITH SAFETY PIN

## PRODUCT FEATURES

Manufactured from low carbon stainless steel EN10088 1.4404 (Marine Grade 316L), which corresponds to UNS S31603, and 316S11

Excellent for lifting applications where a high level of corrosion resistance is required

Meets the performance requirements of EN 13889:2003 and US Federal Specification RR-C-271 Type IVA (Anchor Shackles) and Type IVB (Chain Shackles), Classes 2 (Screw Pin) and 3 (Bolt, Nut and Cotter), Grade A.

Manufactured using the latest technology in electrical upset forging

Factor of Safety 6:1

Available with 2 pin types - safety pin with standard nut (E Type) or nylok nut (E Type-NY)

Special design of bolt ensures the nut is positioned correctly allowing sufficient room for the cotter pin

All shackles CE marked and supplied with instruction leaflet on safe use and storage



D SHACKLE



BOW SHACKLE



PIN

## QUALITY FEATURES

Proof load tested to 2 x WLL and certified at our UK manufacturing facility

Manufactured in accordance with the Machine Directive 2006/42/EC

Inspection certificate BS EN 10204 3.1 provided as standard

High quality finish and excellent polish

## TYPICAL APPLICATIONS

General lifting, including in off-shore applications

Water utility installations and other corrosive facilities, including chemical installations, chlorine plants, etc.

Pump chains and pump lifting

General lifting and tethering in leisure marine applications

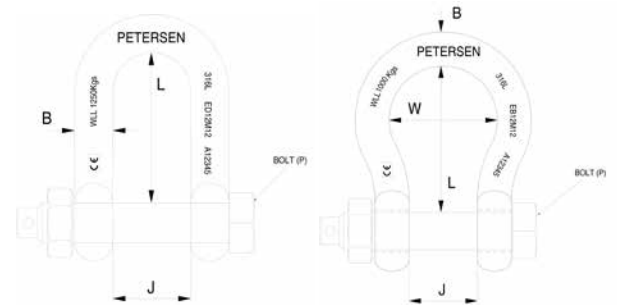

## D SHACKLES

DIMENSIONS (MM) & WLL					PIN STYLES & ITEM CODES		NOMINAL WEIGHT Per Shackle (kg)
WLL (kg)	Bolt Size (P)	Body Dia (B)	Jaw Gap (J)	Length (L)	E Type Pin	E Type Pin c/w Nylok	
350	M6 Bolt	6.0	13.0	25.0	ED6M6	ED6M6-NY	0.05
500	M8 Bolt	8.0	16.0	32.0	ED8M8	ED8M8-NY	0.08
800	M10 Bolt	9.5	19.0	38.0	ED10M10	ED10M10-NY	0.14
1000	M12 Bolt	11.0	22.0	44.0	ED11M12	ED11M12-NY	0.21
1250	M12 Bolt	12.7	26.0	52.0	ED12M12	ED12M12-NY	0.33
1800	M16 Bolt	14.3	29.0	58.0	ED14M16	ED14M16-NY	0.59
2800	M20 Bolt	16.0	32.0	64.0	ED16M20	ED16M20-NY	0.76
3300	M22 Bolt	19.0	38.0	76.0	ED19M22	ED19M22-NY	1.18
4500	M24 Bolt	22.0	44.0	88.0	ED22M24	ED22M24-NY	1.75
5000	M27 Bolt	25.4	50.0	100.0	ED25M27	ED25M27-NY	2.60
7500	M33 Bolt	28.6	57.0	114.0	ED28M33	ED28M33-NY	3.10
10000	M36 Bolt	31.8	64.0	128.0	ED32M36	ED32M36-NY	4.35
12000	M39 Bolt	34.9	70.0	140.0	ED35M39	ED35M39-NY	5.30

## BOW SHACKLES

DIMENSIONS (MM) & WLL						PIN STYLES & ITEM CODES		NOMINAL WEIGHT Per Shackle (kg)
WLL (kg)	Bolt Size (P)	Body Dia (B)	Jaw Gap (J)	Inside Bow (W)	Length (L)	E Type Pin	E Type Pin c/w Nylok	
280	M6 Bolt	6.0	13.0	19.0	28.0	EB6M6	EB6M6-NY	0.05
400	M8 Bolt	8.0	16.0	25.0	35.0	EB8M8	EB8M8-NY	0.08
600	M10 Bolt	9.5	19.0	28.0	38.0	EB10M10	EB10M10-NY	0.15
800	M12 Bolt	11.0	22.0	33.0	46.0	EB11M12	EB11M12-NY	0.22
1000	M12 Bolt	12.7	26.0	38.0	52.0	EB12M12	EB12M12-NY	0.35
1500	M16 Bolt	14.3	29.0	43.0	60.0	EB14M16	EB14M16-NY	0.64
2500	M20 Bolt	16.0	32.0	50.0	68.0	EB16M20	EB16M20-NY	0.81
3000	M22 Bolt	19.0	38.0	58.0	76.0	EB19M22	EB19M22-NY	1.25
4000	M24 Bolt	22.0	44.0	66.0	88.0	EB22M24	EB22M24-NY	1.82
4500	M27 Bolt	25.4	50.0	76.0	100.0	EB25M27	EB25M27-NY	2.70
5500	M33 Bolt	28.6	57.0	86.0	114.0	EB28M33	EB28M33-NY	3.20
7500	M36 Bolt	31.8	64.0	95.0	128.0	EB32M36	EB32M36-NY	4.95
10000	M39 Bolt	34.9	70.0	105.0	140.0	EB35M39	EB35M39-NY	5.40

# MARINE GRADE 316L HIGH CORROSION RESISTANCE STAINLESS STEEL CHAIN LINK D SHACKLES

## PRODUCT FEATURES

Manufactured from low carbon stainless steel EN10088 1.4404 (Marine Grade 316L), which corresponds to UNS S31603, and 316S11

Excellent for lifting applications where a high level of corrosion resistance is required

Manufactured using the latest technology in electrical upset forging

Factor of Safety 6:1

Unique design enabling the shackle to be made captive to a chain sling without the need for welding

The special brace pin allows the shackle to be permanently attached to the chain on site, which results in the shackle becoming part of the chain assembly

The extended load pin is fitted with a split pin to ensure the load pin remains in position, even under vibration

All shackles are CE marked and supplied with instruction leaflet on safe use and storage

## QUALITY FEATURES

Every shackle is proof load tested to 2 x WLL and certified at our UK manufacturing facility

All shackles are manufactured in accordance with the Machine Directive 2006/42/EC

Inspection certificate BS EN 10204 3.1 provided as standard

High quality finish and excellent polish

## TYPICAL APPLICATIONS

Water utility installations & other corrosive facilities

Pump chains and pump lifting



CHAIN LINK SHACKLE

SAFETY PIN

BRACE PIN

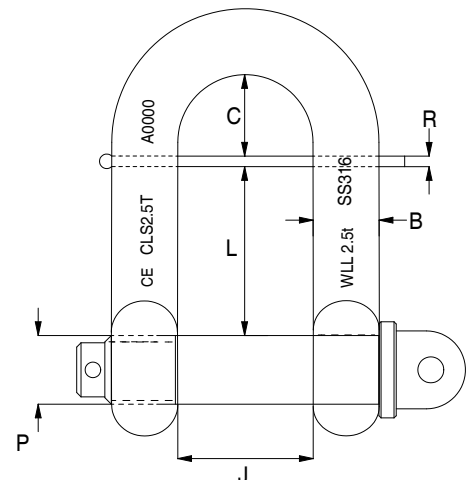

DIMENSIONS (MM) & WLL							ITEM CODES	NOMINAL WEIGHT Per Shackle (kg)
WLL (kg)	Pin Dia (P)	Body Dia (B)	Jaw Gap (J)	Inside L	Brace Pin Dia (R)	C		
1200	12.5	9.5	20.0	25.0	2.0	15.0	CLS1.2T	0.15
2500	19.0	16.0	32.0	40.0	3.0	22.0	CLS2.5T	0.55
3200	22.0	19.0	38.0	45.0	4.0	28.0	CLS3.2T	1.00
5000	25.0	22.0	44.0	55.0	4.0	29.0	CLS5.0T	1.90
6300	28.0	25.0	51.0	65.0	4.0	34.0	CLS6.3T	2.30
9000	35.0	32.0	64.0	125.0	5.0	38.0	CLS9.0T	2.80
12000	38.0	35.0	70.0	137.5	5.0	50.0	CLS12.0T	3.60

## WHY DO WE USE ELECTRICAL UPSET FORGING FOR OUR SHACKLES?

Shackles and other stainless steel items are often produced using welding, casting or drop forging. At Petersen, we use electrical upset forging for a number of key reasons:

### TO MAXIMISE THE STRENGTH AND RELIABILITY OF THE FINISHED PRODUCT

Forged stainless steel shackles are inherently stronger than cast ones (as most low cost shackles are) as they make use of the grain structure of the steel from the drawing process used to produce the blanks. Our method, electrical upset forging, takes it one stage further by ensuring the grain flows around the shackle head to give maximum strength. Furthermore, electrical upsetting does not require further cold-work, which helps to maintain the integrity of the raw material further, which results in benefits for fatigue and corrosion resistance.

### TO PROVIDE THE BEST VALUE PRODUCTS IN THE MARKET

The process of electrical upset forging is very material efficient, reducing waste and ensuring the cost of the item is controlled.

### TO PROVIDE A FLEXIBLE AND RESPONSIVE SERVICE

Upset forging is extremely flexible. We can make shackles on a custom basis to customers requirements in small quantities with little or no tooling cost.

# NSN LOW MAGNETIC PERMEABILITY STAINLESS STEEL D & BOW SHACKLES

## PRODUCT FEATURES

Manufactured from nitronic stainless steel OR stainless steel grade 316 with a magnetic permeability < 1.05G/OE

NSN is a military part code and stands for: National Standard Number (USA) or NATO Stock Number (outside the USA). All NSN shackles are marked with test ID, date of manufacture, WLL in kN, full materials traceability, and manufactured in the UK.

Manufactured using the latest technology in electrical upset forging with a Factor of Safety 6:1

Available with 4 pin types - standard screw collar pin (A Type), extended screw collar pin (AL Type), countersunk head (B Type), safety pin (E Type)



TYPE A TYPE AL TYPE B TYPE E



TYPE A TYPE AL TYPE B TYPE E

## QUALITY FEATURES

Proof load tested to 2 x WLL and certified at our UK manufacturing facility

Manufactured in accordance with the Machine Directive 2006/42/EC

Magnetic permeability test available on request

Inspection certificate BS EN 10204 3.1 provided as standard

High quality finish and excellent polish

## TYPICAL APPLICATIONS

Military, transport and aerospace applications

Lifting or tethering applications where weight is a consideration - nitronic has a high strength to yield ratio

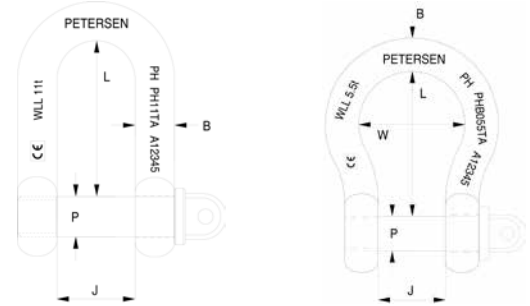

## D SHACKLES

DIMENSIONS (MM) & WLL							ITEM CODES & NSN EQUIVALENT	
WLL (kN)	WLL (T)	Pin Dia (P)	Body Dia (B)	Jaw Gap (J)	Inside Length (L)	MATERIAL	ITEM CODES	NSN EQUIVALENT
5.6	0.575	12.7	10.0	16.0	38.0	AISI 316	LMD-5777	0579-91-539-5777
6.3	0.642	12.7	10.0	17.0	36.0	AISI 316	LMD-6655	4030-99-149-6655
9.9	1.015	16.0	12.7	21.0	46.0	AISI 316	LMD-5778	0579-91-539-5778
10.0	1.019	16.0	12.7	21.0	49.0	AISI 316	LMD-6657	4030-99-149-6657
12.3	1.250	12.7	12.7	26.0	53.0	AISI 316	LMD-6395	4030-99-820-6395
15.6	1.590	19.0	16.0	26.0	57.0	AISI 316	LMD-5779	0579-91-539-5779
16.0	1.632	19.0	16.0	27.0	61.0	AISI 316	LMD-5604	4030-99-129-5604
20.0	2.094	22.0	19.0	30.0	68.0	AISI 316	LMD-6509	4030-99-149-6509
25.0	2.549	25.4	22.0	33.0	73.0	AISI 316	LMD-6679	4030-99-149-6679
30.5	3.110	29.0	22.0	36.0	81.0	AISI 316	LMD-5780	0579-91-539-5780
31.5	3.212	28.0	25.4	38.0	84.0	AISI 316	LMD-9819	4030-99-137-9819
40.0	4.079	32.0	28.0	42.0	91.0	AISI 316	LMD-6500	4030-99-149-6500
50.0	5.098	35.0	32.0	47.0	111.0	AISI 316	LMD-1952	4030-99-151-1952
50.5	5.150	35.0	29.0	46.0	103.0	AISI 316	LMD-1065	0579-91-539-1065
63.0	6.424	38.0	35.0	53.0	120.0	AISI 316	LMD-6499	4030-99-149-6499
89.7	9.150	48.0	38.0	61.0	138.0	AISI 316	LMD-4700	0579-91-539-4700

## BOW SHACKLES

DIMENSIONS (MM) & WLL							ITEM CODES & NSN EQUIVALENT		
WLL (kN)	WLL (T)	Pin Dia (P)	Body Dia (B)	Jaw Gap (J)	Inside Length	Bow Width (W)	Material	ITEM CODES	NSN EQUIVALENT
5.88	0.6	12.7	9.5	16.6	36.5	24.0	Nitronic	LMB-5480	4030-00-270-5480
8.04	0.82	12.7	11.1	18.3	42.8	30.0	Nitronic	LMB-5481	4030-00-270-5481
10.49	1.07	16.0	12.7	26.9	42.8	35.0	Nitronic	LMB-5482	4030-00-270-5482
10.0	1.019	16.0	12.7	22.0	52.0	36.0	AISI 316	LMB-6785	4030-99-149-6785
6.6	0.635	16.0	12.7	24.0	51.0	38.0	AISI 316	LMB-5776	057-99-539-5776
9.9	1.015	19.0	19.0	29.0	64.0	48.0	AISI 316	LMB-5775	057-91-539-5775
16.0	1.606	19.0	16.0	27.0	58.0	40.0	AISI 316	LMB-6619	4030-99-149-6619
16.35	1.667	19.0	16.0	26.9	63.5	38.0	Nitronic	LMB-5483	4030-00-270-5483
23.58	2.404	22.0	19.0	31.7	76.2	45.0	Nitronic	LMB-5484	4030-00-270-5484
32.06	3.269	25.4	22.0	36.5	82.5	57.0	Nitronic	LMB-5485	4030-00-270-5485
25.0	2.549	25.4	22.0	33.0	73.0	49.0	AISI 316	LMB-6637	4030-99-149-6637
29.8	3.039	25.0	25.0	39.0	80.0	59.0	AISI 316	LMB-2573	4030-12-166-2573
31.5	3.212	28.0	25.4	38.0	82.0	54.0	AISI 316	LMB-25	-
40.0	4.079	32.0	28.0	42.0	90.0	60.0	AISI 316	LMB-28	-
24.9	2.540	32.0	25.4	46.0	102.0	76.0	AISI 316	LMB-1061	057-91-537-1061
50.0	5.098	35.0	32.0	47.0	110.0	70.0	AISI 316	LMB-1962	4030-99-151-1962



# DUPLEX AND SUPER DUPLEX WLL SCREW D & BOW SHACKLES

## PRODUCT FEATURES

Manufactured from super duplex stainless steel EN 1.4501, UNS S 32760, SAF 2507® or standard duplex stainless steel EN 1.4462Z, UNS 31803, SAF 2205®

Designed for use in high salinity, harsh chemical and sub-sea environments

Manufactured using the latest technology in forging with a Factor of Safety 6:1

Available with 2 pin types - standard screw collar pin (A Type) and countersunk head (B Type)

All shackles CE marked and supplied with instruction leaflet on safe use and storage

## TYPICAL APPLICATIONS

General lifting in tropical marine environments, e.g. Arabian Gulf

Corrosive facilities, including chemical installations, desalination pumps, etc.

Sub-sea tethering, tethering of sea-state monitoring equipment, ROV and sonar array

Pump chains and pump lifting

## QUALITY FEATURES

Proof load tested to 2 x WLL and certified at our UK manufacturing facility

Manufactured in accordance with the Machine Directive 2006/42/EC

Inspection certificate BS EN 10204 3.1 provided as standard

High quality finish and excellent polish

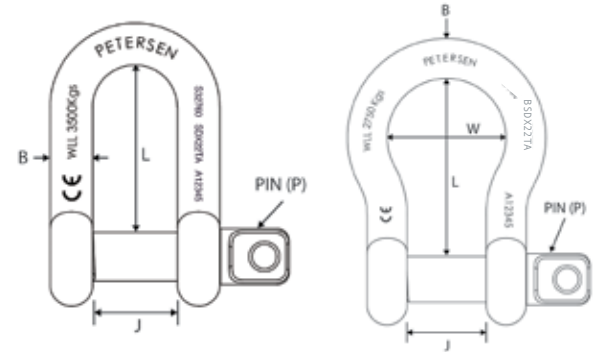

## D SHACKLES

DIMENSIONS (MM) & WLL					PIN STYLES & ITEM CODES		NOMINAL WEIGHT Per Shackle (kg)
WLL (kg)	Pin Dia (P)	Body Dia (B)	Jaw Gap (J)	Length (L)	A Type Pin	B Type Pin	
130	4.0	4.0	8.0	16.0	SDX04TA	SDX04TB	0.01
200	5.0	5.0	10.0	20.0	SDX05TA	SDX05TB	0.01
325	6.0	6.0	13.0	25.0	SDX06TA	SDX06TB	0.02
500	8.0	8.0	16.0	32.0	SDX08TA	SDX08TB	0.05
800	9.5	9.5	19.0	38.0	SDX10TA	SDX10TB	0.10
1000	11.0	11.0	22.0	44.0	SDX11TA	SDX11TB	0.15
1250	12.7	12.7	26.0	52.0	SDX12TA	SDX12TB	0.24
1660	16.0	14.3	29.0	58.0	SDX16TA	SDX16TB	0.45
2330	19.0	16.0	32.0	64.0	SDX19TA	SDX19TB	0.59
3500	22.2	19.0	38.0	76.0	SDX22TA	SDX22TB	1.00
4500	25.4	22.2	44.0	88.0	SDX25TA	SDX25TB	1.90
5500	28.6	25.4	51.0	102.0	SDX28TA	SDX28TB	2.90
6500	31.8	28.6	57.0	114.0	SDX32TA	SDX32TB	3.10
7500	34.9	31.8	64.0	128.0	SDX35TA	SDX35TB	4.35
9000	38.0	34.9	70.0	140.0	SDX38TA	SDX38TB	5.30

To order a Duplex shackle, remove the S from the item code, e.g. SDX04TA becomes **DX04TA**.

## BOW SHACKLES

DIMENSIONS (MM) & WLL						PIN STYLES & ITEM CODES		NOMINAL WEIGHT Per Shackle (kg)
WLL (kg)	Pin Dia (P)	Body Dia (B)	Jaw Gap (J)	Inside Bow (W)	Length (L)	A Type Pin	B Type Pin	
130	4.0	4.0	8.0	12.0	16.0	BSDX04TA	BSDX04TB	0.01
200	5.0	5.0	10.0	16.0	22.0	BSDX05TA	BSDX05TB	0.01
260	6.0	6.0	13.0	19.0	28.0	BSDX06TA	BSDX06TB	0.03
400	8.0	8.0	16.0	25.0	35.0	BSDX08TA	BSDX08TB	0.06
630	9.5	9.5	19.0	28.0	38.0	BSDX10TA	BSDX10TB	0.11
800	11.0	11.0	22.0	33.0	46.0	BSDX11TA	BSDX11TB	0.16
1000	12.7	12.7	26.0	38.0	52.0	BSDX12TA	BSDX12TB	0.27
1330	16.0	14.3	29.0	43.0	60.0	BSDX16TA	BSDX16TB	0.50
2000	19.0	16.0	32.0	50.0	68.0	BSDX19TA	BSDX19TB	0.63
2750	22.2	19.0	38.0	57.0	76.0	BSDX22TA	BSDX22TB	1.05
3750	25.4	22.2	44.0	66.0	88.0	BSDX25TA	BSDX25TB	2.00
4500	28.6	25.4	51.0	76.0	102.0	BSDX28TA	BSDX25TB	3.05
5500	31.8	28.6	57.0	86.0	114.0	BSDX32TA	BSDX32TB	3.26
6500	34.9	31.8	64.0	95.0	128.0	BSDX35TA	BSDX35TB	4.57
7500	38.0	34.9	70.0	105.0	140.0	BSDX38TA	BSDX38TB	5.57

To order a Duplex shackle, remove the S from the item code, e.g. BSDX04TA becomes **BDX04TA**.

# BLACK FINISH 17/4PH HIGH TENSILE STAINLESS STEEL D & BOW SHACKLES

## PRODUCT FEATURES

We offer our full size range of 17/4PH stainless steel shackles (see page 4) in a robust flat black (RAL 9021) Tufftride finish

Available with 2 pin types - standard screw collar pin (A Type) and standard nut pin (E Type). The screw pin enables quick (dis)assembly which makes the shackle perfect for rigging activities in which assembly and disassembly occur relatively frequently.

Manufactured using the latest technology in electrical upset forging before undergoing an environmentally-friendly salt bath Nitrocarburising process, followed by oxidizing quenching

Factor of Safety 6:1

Working Load Limit permanently shown on every shackle

Supplied with proof load certificate, material certificate available on request

## WHAT IS TUFFTRIDE®?

Tufftride®, also known as Tenifer® is the trade name for a thermo-chemical surface treatment where stainless steel items undergo salt bath Nitrocarburising.

## THE BENEFITS OF TUFFTRIDE

Gives a very hard (800-1500Hv) wearing resistant surface to the metal typically up to a depth of 0.002" (0.05mm) depending upon the material.

The surface layer is in compression and so not conducive to crack initiation. This increases fatigue resistance.

As the process is carried out at 580°C, no phase changes take place as is the case with higher temperature treatments, and so there is little or no dimensional change in the components.

The process gives components improved corrosion resistance.

The hard wear resistant surface also exhibits self-lubricating and anti-seize properties, ideal for threaded components.

## QUALITY FEATURES

Proof load tested to 2 x WLL and certified at our UK manufacturing facility

Manufactured in accordance with the Machine Directive 2006/42/EC

Meets the performance requirements of EN 13889:2003 and US Federal Specification RR-C-271 Type IVA (Anchor Shackles) and Type IVB (Chain Shackles), Classes 2 (Screw Pin) and 3 (Bolt, Nut and Cotter), Grade A.

Inspection certificate BS EN 10204 3.1 available on request

High quality flat finish

## TYPICAL APPLICATIONS

Lifting or tethering applications where sheen or reflections are unwanted for aesthetic purposes, e.g. theatrical rigging, or tactical purposes, e.g. in military applications

Applications where components may suffer from wear, corrosion, seizure or galling



## MATERIAL MATTERS

We manufacture products from a wide range of types of stainless steel to suit different applications. Explore some of our options below or speak direct to our team for information and support choosing the correct material.

### 17/4PH

The PH stands for precipitation-hardening. 17/4PH has almost double the working load limit (WLL) of 316L, so for a given WLL, a PH shackle will be a lighter option.

### MARINE GRADE 316L (EN 10088 1.4404)

This low carbon stainless steel has better corrosion resistance than 17/4PH, and is suitable for applications that require long-term submersion, although not in high salinity or deep water, or aggressive chemical environments.

### DUPLEX

With 21-22% chrome, Duplex is often specified for high salinity environments, such as sea water pumps.

### SUPER DUPLEX (SDX) (EN 10088 1.4501, S32760)

The higher percentage of chrome (23-25%) in SDX makes it extremely corrosion resistant, and therefore ideally suited to low oxygen environments, such as deep sea.

### NITRONIC

Often used as an alternative for Duplex stainless steel, especially in the USA.

# STAINLESS STEEL SWING / EYE BOLTS TO DIN 444 TYPE A, TYPE B AND TYPE C

## PRODUCT FEATURES

- Stainless steel eye bolts to DIN 444 pattern
- Manufactured from 316L stainless steel (1.4404)
- Available as standard from M6 up to M24
- Other sizes and custom lengths on request
- Available in other materials including duplex grades
- Excellent grain structure resists corrosion and fatigue

## QUALITY FEATURES

- Upset forged with rolled threads for high strength
- Manufactured in the UK
- Full materials traceability as standard - material and conformity certificates available on request

## TYPICAL APPLICATIONS

- Swing bolts on food storage and processing equipment
- Chemical processing plants
- Securing lids on centrifuge equipment
- Paper and wood-pulp mills

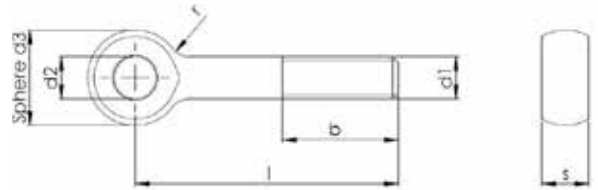

SPECIFICATIONS											ITEM CODE	
d1			l		b	d2 Nominal	d3 Nominal	r Nominal	s			MBL (kN)
Metric Coarse	UNC	UNF	Short/Long	Nominal					Type A	Type B & Type C		
M6 x 1.0	1/4-20	1/4-28	Short	40.0	18.0	6.0	14.0	4.0	9	7	12.1	SWB444A-##-40
M6 x 1.0	1/4-20	1/4-28	Long	60.0	18.0	6.0	14.0	4.0	9	7	12.1	SWB444A-##-60
M8 x 1.25	5/16-18	5/16-24	Short	50.0	22.0	8.0	18.0	4.0	11	9	22.0	SWB444##-##-50
M8 x 1.25	5/16-18	5/16-24	Long	70.0	22.0	8.0	18.0	4.0	11	9	22.0	SWB444A-##-70
M10 x 1.5	3/8-16	3/8-24	Short	60.0	26.0	10.0	20.0	4.0	14	12	34.8	SWB444A-##-60
M10 x 1.5	3/8-16	3/8-24	Long	80.0	26.0	10.0	20.0	4.0	14	12	34.8	SWB444A-##-80
M12 x 1.75	1/2-13	1/2-20	Short	70.0	30.0	12.0	25.0	6.0	17	14	50.6	SWB444A-##-70
M12 x 1.75	1/2-13	1/2-20	Long	100.0	30.0	12.0	25.0	6.0	17	14	50.6	SWB444A-##-100
M16 x 2.0	5/8-11	5/8-18	Short	80.0	38.0	16.0	32.0	6.0	19	17	94.2	SWB444A-##-80
M16 x 2.0	5/8-11	5/8-18	Long	120.0	38.0	16.0	32.0	6.0	19	17	94.2	SWB444A-##-120
M20 x 2.5	3/4-10	3/4-16	Short	100.0	46.0	18.0	40.0	6.0	24	22	147.0	SWB444A-##-100
M20 x 2.5	3/4-10	3/4-16	Long	140.0	52.0	18.0	40.0	6.0	24	22	147.0	SWB444A-##-140
M24 x 3.0	1-8	1-12	Short	120.0	54.0	22.0	45.0	10.0	28	25	211.8	SWB444A-##-120
M24 x 3.0	1-8	1-12	Long	160.0	60.0	22.0	45.0	10.0	28	25	211.8	SWB444A-##-160

To order different thread types, please replace ## in the item code with the required thread size and type, without special characters, e.g. SWB444A-M6-40, SWB444A-UNC1420-40, or SWB444A-UNF1428-40.

To order different types, please replace A in the item code with the required Type, e.g. SWB444A-M6-40, SWB444B-M6-40, or SWB444C-M6-40.

## TOLERANCE CLASSES

DIN 444 specifies three different eye bolts, Type A, Type B and Type C. The relevant tolerances are given below:

	l	d2	d3	s
Type A	± 1.05	H9	h16	h14
Type B	± 0.65	H9	h14	h12
Type C	± 0.40	H9	h14	h12

# STAINLESS STEEL DIN 580:2010 EYE BOLTS & DIN 582:2010 EYE NUTS

## PRODUCT FEATURES

Manufactured from 316 stainless steel

Passivated, as required by the technical standards, providing good protection from the weather and from oxidation

Manufactured using hot-forging, not die-casting

Etched with CE marking, the manufacturer's mark, steel type, thread size, WLL in kg, and an arrow indicating the pull, plus manufacturing batch number

CE marked and supplied with instruction leaflet on safe use and storage

## QUALITY FEATURES

Proof load tested to 2 x WLL and certified at our UK manufacturing facility

Manufactured in accordance with the Machine Directive 2006/42/EC

Inspection certificate BS EN 10204 3.1 provided as standard

High quality finish and excellent polish

## TYPICAL APPLICATIONS

General lifting applications

Lifting machinery, appliances or other objects which cannot be lifted by hand or by fork lift truck

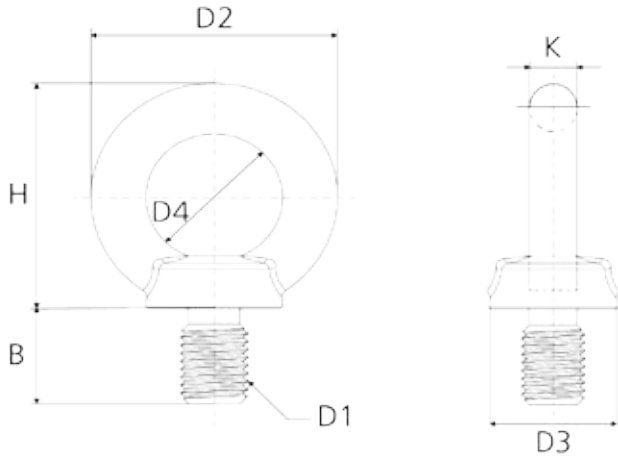

LIFTING EYE BOLT DIN 580:2010

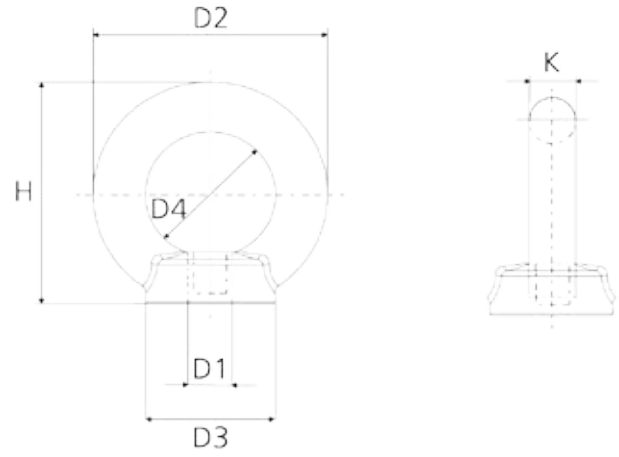

LIFTING EYE NUT DIN 582:2010

## WORKING LOADS & BREAKING LOADS

The following working loads (WLL) are valid for eye bolts DIN 580:2010 and for eye nuts DIN 582:2010 made of C15E steel and A2/A3/A4 stainless steel. When subjected to proof loading as specified in DIN EN 898-1, the minimum breaking load (MBL) of eye bolts is as below:

	THREAD & WLL (KG)			MBL (kN)	
	LIFTING CAPACITY (KG) PER LIFTING EYE	LIFTING CAPACITY (KG) PER LIFTING EYE	LIFTING CAPACITY (KG) PER LIFTING EYE FITTED AT SIDES OF LOAD	STRAIGHT LIFTING	90° LIFTING
THREAD					
M8	140	100	70	8.20	4.10
M10	230	170	115	13.50	6.80
M12	340	240	170	20.00	10.00
M16	700	500	350	41.20	20.60
M20	1200	860	600	70.60	35.30
M24	1800	1290	900	105.90	53.00
M30	3200	2300	1600	188.30	94.20
M36	4600	3300	2300	270.70	135.40
M42	6300	4500	3150	370.70	185.40
M48	8600	6100	4300	506.00	253.00
M56	11500	8200	5750	676.70	338.40
M64	16000	11000	8000	941.40	470.70
M72x6	20000	14000	10000	1176.80	588.40
M80x6	28000	20000	14000	1647.50	823.80
M100x6	40000	29000	20000	2353.60	1176.80

# STAINLESS STEEL DIN 580:2010 EYE BOLTS & DIN 582:2010 EYE NUTS

## LIFTING EYE BOLT DIN 580:2010

DIMENSIONS (MM)							ITEM CODES
D1 THREAD SIZE	D2 nominal	D3 nominal	D4 nominal	H nominal	K nominal	B nominal	
M8	36	20	20	36	8	13	580M8-0140
M10	45	25	25	45	10	17	580M10-0230
M12	54	30	30	53	12	20,5	580M12-0340
M16	63	35	35	62	14	27	580M16-0700
M20	72	40	40	71	16	30	580M20-1200
M24	90	50	50	90	20	36	580M24-1800
M30	108	65	60	109	24	45	580M30-3600
M36	126	75	70	128	28	54	580M36-4600
M42	144	85	80	147	32	63	580M42-6300
M48	166	100	90	168	38	68	580M48-8600
M56	184	110	100	187	42	78	ON REQUEST
M64	206	120	110	208	48	90	ON REQUEST
M72x6	260	150	140	260	60	100	ON REQUEST
M80x6	296	170	160	298	68	112	ON REQUEST
M100x6	330	190	180	330	75	130	ON REQUEST

## LIFTING EYE NUT DIN 582:2010

DIMENSIONS (MM)						ITEM CODES
D1 THREAD SIZE	D2 nominal	D3 nominal	D4 nominal	H nominal	K nominal	
M8	36	20	20	36	8	582M8-0140
M10	45	25	25	45	10	582M10-0230
M12	54	30	30	53	12	582M12-0340
M16	63	35	35	62	14	582M16-0700
M20	72	40	40	71	16	582M20-1200
M24	90	50	50	90	20	582M24-1800
M30	108	65	60	109	24	582M30-3200
M36	126	75	70	128	28	582M36-4600
M42	144	85	80	147	32	582M42-6300
M48	166	100	90	168	38	582M48-8600
M56	184	110	100	187	42	ON REQUEST
M64	206	120	110	208	48	ON REQUEST
M72x6	260	150	140	260	60	ON REQUEST
M80x6	296	170	160	298	68	ON REQUEST
M100x6	330	190	180	330	75	ON REQUEST

# STAINLESS STEEL CENTRE SWIVEL LIFTING POINTS

## PRODUCT FEATURES

Manufactured from 316L stainless steel (1.4404)

Available as standard with threads from M8 up to M30; other sizes and custom lengths on request

Available in other materials including duplex grades

The standard finished is polished, but we can supply with a coloured coating if required

Excellent grain structure resists corrosion and fatigue

The lifting shackle pivots 180° and the base swivels 360° simultaneously to allow lifting from any direction



## QUALITY FEATURES

Proof load tested to 2 x WLL and certified at our UK manufacturing facility

Manufactured in accordance with the Machine Directive 2006/42/EC

Inspection certificate BS EN 10204 3.1 provided as standard

High quality finish and excellent polish

## TYPICAL APPLICATIONS

Applications where a fixed lifting point is unsuitable, e.g. lifting loads at angles, especially when load movement or turning might be encountered

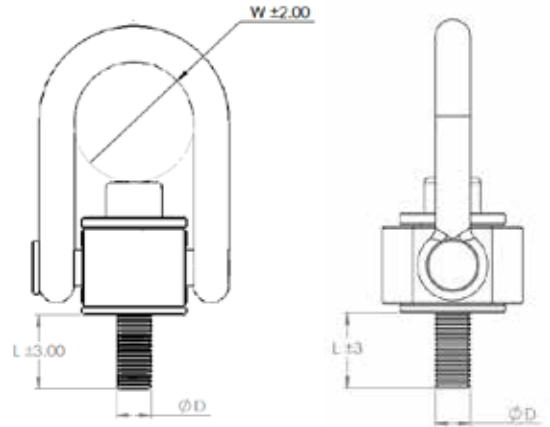

THREAD, DIMENSIONS (MM) & WLL						ITEM CODES	NOMINAL WEIGHT (KG)
Thread	D Thread dia	W	L	WLL SF 4:1 (Tonnes)	WLL SF 6:1 (Tonnes)		
M8	8	24	16	0.30	0.20	DLS-C-M8	0.30
M10	10	30	20	0.50	0.33	DLS-C-M10	0.32
M12	12	36	24	0.80	0.53	DLS-C-M12	0.33
M14	14	42	28	1.00	0.66	DLS-C-M14	0.52
M16	16	48	32	1.50	1.00	DLS-C-M16	1.30
M18	18	54	36	1.50	1.00	DLS-C-M18	1.30
M20	20	60	40	1.60	1.10	DLS-C-M20	1.30
M22	22	66	44	2.20	1.46	DLS-C-M22	1.40
M24	24	72	48	2.70	1.60	DLS-C-M24	1.50
M27	27	81	54	2.90	1.93	DLS-C-M27	2.20
M30	30	90	60	3.50	2.23	DLS-C-M30	3.30

## WORKING LOADS (FACTOR OF SAFETY 6:1)

The following working loads (WLL) for centre swivel lifting points are as below:

THREAD	THREAD & WLL						
	1 leg; 0° angle of inclination; Factor: 1	1 leg; 90° angle of inclination; Factor: 1	2 legs; 0° angle of inclination; Factor: 2	2 legs; 90° angle of inclination; Factor: 2	2 legs; 0°-45°; Factor: 1.4	2 legs; 45°-60°; Factor: 1	2 legs; Unsymmetrical lift; Factor: 1
	WLL IN TONNES						
M8	0.20	0.20	0.40	0.40	0.28	0.20	0.20
M10	0.33	0.33	0.66	0.66	0.46	0.33	0.33
M12	0.53	0.53	1.06	1.06	0.74	0.53	0.53
M14	0.66	0.66	1.32	1.32	0.92	0.66	0.66
M16	1.00	1.00	2.00	2.00	1.40	1.00	1.00
M18	1.00	1.00	2.00	2.00	1.40	1.00	1.00
M20	1.10	1.10	2.20	2.20	1.54	1.10	1.10
M22	1.46	1.46	2.92	2.92	2.04	1.46	1.46
M24	1.60	1.60	3.20	3.20	2.24	1.60	1.60
M27	1.93	1.93	3.86	3.86	2.70	1.93	1.93
M30	2.23	2.23	4.46	4.46	3.12	2.23	2.23

Please note, if the Factor of Safety used is 4:1, the factor remains the same, e.g. for 1 leg with 0° angle of inclination, the factor is 1.

# STAINLESS STEEL U BOLTS

## PRODUCT FEATURES

- Manufactured from stainless steel EN10088 1.4404 (Marine Grade 316L)
- Excellent for applications where a high level of corrosion resistance is required
- Counter plates make the U bolt extra secure
- Other sizes and custom lengths on request
- Available in other materials including duplex grades
- Excellent grain structure resists corrosion and fatigue



## QUALITY FEATURES

- Bent with rolled threads for high strength
- Manufactured in accordance with the Machine Directive 2006/42/EC
- Full materials traceability as standard - material and conformity certificates available on request
- High quality finish and excellent polish

## TYPICAL APPLICATIONS

- Fastening applications, e.g. lifelines, cable or rope securing
- Supporting or securing pipework

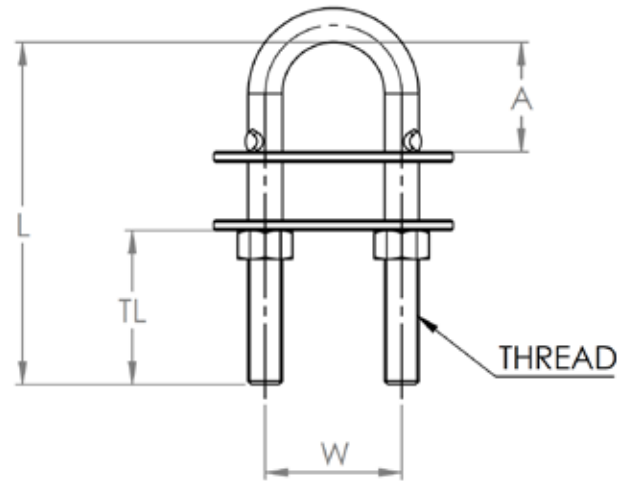

DIMENSIONS (MM) & WLL (KG)						ITEM CODES
Thread	WLL (KG)	Inside Length (A)	Overall Length (L)	Thread Length (TL)	Leg Centres (W)	
M4 x 0.70	480	21	50	27	24	UB4-24-50
M5 x 0.80	640	24	60	30	28	UB5-28-60
M6 x 1.0	1280	27	70	35	32	UB6-32-70
M6 x 1.0	1280	27	90	55	32	UB6-32-90
M8 x 1.25	2400	30	80	40	36	UB8-36-80
M8 x 1.25	2400	30	100	60	36	UB8-36-100
M10 x 1.5	3600	32	90	45	40	UB10-40-90
M10 x 1.5	3600	32	110	65	40	UB10-40-110
M12 x 1.75	6400	34	110	50	44	UB12-44-110
M12 x 1.75	6400	34	130	70	44	UB12-44-130

# HIGH CORROSION RESISTANCE 316L STAINLESS STEEL TESTED TURNBUCKLES

## PRODUCT FEATURES

Manufactured from stainless steel EN10088 1.4404 (Marine Grade 316L)  
 Excellent for lifting applications where a high level of corrosion resistance is required  
 Factor of Safety 6:1  
 All CE marked and supplied with instruction leaflet on safe use and storage

## QUALITY FEATURES

Proof load tested to 2 x WLL and certified at our UK manufacturing facility  
 Manufactured in accordance with the Machine Directive 2006/42/EC  
 Inspection certificate BS EN 10204 3.1 provided as standard  
 High quality finish and excellent polish

## TYPICAL APPLICATIONS

General lifting, including in off-shore applications  
 Water utility installations and other corrosive facilities, including chemical installations, chlorine plants, etc.  
 General lifting and tethering in leisure marine applications

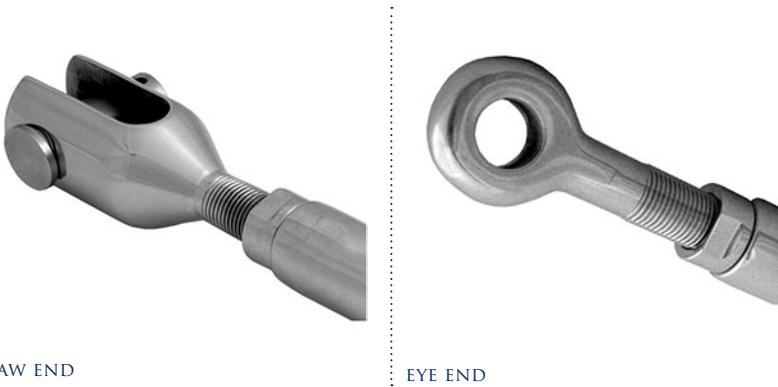

## JAW/JAW TURNBUCKLE



DIMENSIONS (MM) & WLL								ITEM CODES	NOMINAL WEIGHT Per Item (kg)
Thread	WLL (kg)	Wire Dia	Pin (P)	C	T	Min L	Max L		
1/4"unf	200	3.0	6.0	12.5	6.2	135	205	RSFF03-WLL	0.08
5/16"unf	325	4.0	8.0	17.0	7.9	165	240	RSFF04-WLL	0.17
3/8"unf	500	5.0	9.5	19.0	9.9	200	300	RSFF05-WLL	0.28
7/16"unf	700	6.0	11.0	20.0	10.9	220	330	RSFF06-WLL	0.40
1/2"unf	825	7.0	12.0	25.0	12.7	260	390	RSFF07-WLL	0.61
5/8"unf	1325	8.0	14.0	28.0	13.5	325	480	RSFF08-WLL	1.26
5/8"unf	1325	10.0	16.0	32.0	15.8	345	500	RSFF10-WLL	1.43
3/4"unf	1825	12.0	19.0	38.0	17.8	400	570	RSFF12-WLL	2.42
7/8"unf	2500	14.0	22.0	45.0	22.0	450	640	RSFF14-WLL	3.58
1"unf	3300	16.0	25.0	50.0	25.0	520	760	RSFF16-WLL	5.34
1 1/8"unf	4300	19.0	28.0	58.0	28.2	585	855	RSFF19-WLL	8.20
1 1/4"unf	5500	22.0	32.0	64.0	31.5	635	920	RSFF22-WLL	10.71
1 3/8"unf	7600	26.0	35.0	70.0	34.8	715	1040	RSFF26-WLL	14.09



# HIGH CORROSION RESISTANCE 316L STAINLESS STEEL TESTED TURNBUCKLES

## JAW/EYE TURNBUCKLE



DIMENSIONS (MM) & WLL									ITEM CODES	NOMINAL WEIGHT Per Item (kg)
Thread	WLL (kg)	Wire Dia.	Pin (P)	H	C	T	Min L	Max L		
1/4"unf	200	3.0	6.0	6.35	12.5	6.2	127.0	197.0	RSFE03-WLL	0.07
5/16"unf	325	4.0	8.0	8.00	17.0	7.9	154.0	232.0	RSFE04-WLL	0.14
3/8"unf	500	5.0	9.5	9.53	19.0	9.9	189.0	289.0	RSFE05-WLL	0.24
7/16"unf	700	6.0	11.0	11.10	20.0	10.9	207.0	316.0	RSFE06-WLL	0.33
1/2"unf	825	7.0	12.0	12.70	25.0	12.7	244.0	376.0	RSFE07-WLL	0.52
5/8"unf	1325	8.0	14.0	14.30	28.0	13.5	300.0	456.0	RSFE08-WLL	1.09
5/8"unf	1325	10.0	16.0	16.00	32.0	15.8	325.0	380.0	RSFE10-WLL	1.20
3/4"unf	1825	12.0	19.0	19.05	38.0	17.8	373.0	544.0	RSFE12-WLL	1.95
7/8"unf	2500	14.0	22.0	22.20	45.0	22.0	415.0	610.0	RSFE14-WLL	3.05
1"unf	3300	16.0	25.0	25.40	50.0	25.0	485.0	724.0	RSFE16-WLL	4.41
1 1/8"unf	4300	19.0	28.0	28.58	58.0	28.2	548.0	818.0	RSFE19-WLL	4.36
1 1/4"unf	5500	22.0	32.0	32.00	64.0	31.8	595.0	879.0	RSFE22-WLL	5.99
1 3/8"unf	7600	26.0	35.0	35.00	70.0	34.8	672.0	996.0	RSFE26-WLL	12.12

## EYE/EYE TURNBUCKLE



DIMENSIONS (MM) & WLL							ITEM CODES	NOMINAL WEIGHT Per Item (kg)
Thread	WLL (kg)	Wire Dia.	H	T	Min L	Max L		
1/4"unf	200	3.0	6.35	5.0	120.0	190.0	RSEE03-WLL	0.05
5/16"unf	325	4.0	8.00	6.5	143.0	221.0	RSEE04-WLL	0.10
3/8"unf	500	5.0	9.53	7.8	177.0	277.0	RSEE05-WLL	0.19
7/16"unf	700	6.0	11.10	9.5	193.0	301.0	RSEE06-WLL	0.27
1/2"unf	825	7.0	12.70	11.5	221.0	363.0	RSEE07-WLL	0.43
5/8"unf	1325	8.0	14.30	13.5	279.0	435.0	RSEE08-WLL	0.93
5/8"unf	1325	10.0	16.00	15.0	303.0	459.0	RSEE10-WLL	0.96
3/4"unf	1825	12.0	19.05	17.5	346.0	517.0	RSEE12-WLL	1.49
7/8"unf	2500	14.0	22.20	21.5	383.0	580.0	RSEE14-WLL	2.52
1"unf	3300	16.0	25.40	23.5	452.0	691.0	RSEE16-WLL	3.47
1 1/8"unf	4300	19.0	28.58	27.5	510.0	780.0	RSEE19-WLL	3.71
1 1/4"unf	5500	22.0	32.00	31.0	557.0	841.0	RSEE22-WLL	4.27
1 3/8"unf	7600	26.0	35.00	33.5	628.0	952.0	RSEE26-WLL	10.16

# STAINLESS STEEL WIRE ROPES (AISI 316)

## PRODUCT FEATURES

Sold as bespoke lengths to suit application or in 250m and 500m reels

Austenitic condition to give maximum corrosion resistance

Wire rope slings available, cut and manufactured to custom lengths

We offer a wide range of stainless steel wire ropes for all applications. Please contact us for other wire sizes and constructions.

## QUALITY FEATURES

Sourced from EU steel mills

Dimensions and tensile grades conforming to BS MA 29

Stainless steel wire rope manufactured in accordance to EN 10264-1/4

Stainless steel wire rope with construction 7X19 manufactured in accordance to EN12385-4

Material certificates available on request

High quality finish and excellent polish

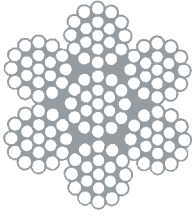

7X19

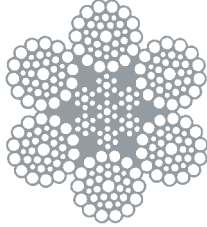

6X36WS + IWRC

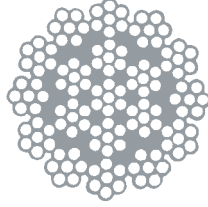

18X7 + IWRC  
(ROTATION RESISTING)

## CONSTRUCTION 7X19

SPECIFICATION				ITEM CODES
Diameter (mm)	MBL (kN)	MBL (kg)	Weight (kg/100m)	
1.5	1.25	128	0.90	WR015(7x19)
2.0	2.08	212	1.49	WR02(7x19)
2.5	3.26	332	2.33	WR025(7x19)
3.0	4.69	478	3.35	WR03(7x19)
3.5	6.39	652	4.56	WR035(7x19)
4.0	8.34	850	5.95	WR04(7x19)
5.0	13.00	1,330	9.30	WR05(7x19)
6.0	18.80	1,920	13.40	WR06(7x19)
7.0	25.50	2,600	18.20	WR07(7x19)
8.0	33.40	3,410	23.80	WR08(7x19)
10.0	52.10	5,310	37.20	WR10(7x19)
12.0	75.10	7,660	53.60	WR12(7x19)
14.0	102.0	10,100	72.90	WR14(7x19)
16.0	133.0	13,600	95.50	WR16(7x19)

## CONSTRUCTION 6X36WS + IWRC

SPECIFICATION				ITEM CODES
Diameter (mm)	MBL (kN)	MBL (kg)	Weight (kg/100m)	
6.0	20.08	2,047	14.6	WR06(6x36)-I
8.0	35.70	3,641	26.0	WR08(6x36)-I
10.0	55.90	5,700	40.9	WR10(6x36)-I
12.0	80.50	8,210	58.9	WR12(6x36)-I
14.0	110.0	11,200	80.2	WR14(6x36)-I
16.0	143.0	14,600	105.0	WR16(6x36)-I
18.0	181.0	18,500	133.0	WR18(6x36)-I
20.0	224.0	22,800	164.0	WR20(6x36)-I
22.0	271.0	27,600	198.0	WR22(6x36)-I
24.0	322.0	32,800	236.0	WR24(6x36)-I
26.0	354.0	36,100	276.0	WR26(6x36)-I
28.0	410.0	41,800	321.0	WR28(6x36)-I
30.0	471.0	48,000	368.0	WR30(6x36)-I

## CONSTRUCTION 18X7 + IWRC (ROTATION RESISTING)

SPECIFICATION				ITEM CODES
Diameter (mm)	MBL (kN)	MBL (kg)	Weight (kg/100m)	
3.0	4.66	475	4.8	WR03(18x7)-I
4.0	8.50	867	6.4	WR04(18x7)-I
5.0	12.90	1,320	10.0	WR05(18x7)-I
6.0	18.50	1,890	14.4	WR06(18x7)-I
7.0	25.20	2,570	19.6	WR07(18x7)-I
8.0	33.0	3,370	25.7	WR08(18x7)-I
10.0	51.50	5,250	40.1	WR10(18x7)-I
12.0	74.20	7,570	57.7	WR12(18x7)-I
14.0	100.90	10,289	75.2	WR14(18x7)-I
16.0	129.30	13,179	101.5	WR16(18x7)-I

# STAINLESS STEEL THIMBLES & STAINLESS STEEL WIRE ROPE CLIPS (BULLDOG GRIPS) TO DIN 741

## PRODUCT FEATURES

- Free from sharp edges, with a smooth finish all round
- High corrosion resistance
- Wire rope grips are manufactured to DIN 741

## QUALITY FEATURES

- Manufactured in accordance with the Machine Directive 2006/42/EC
- Inspection certificate BS EN 10204 3.1 provided as standard
- High quality finish and excellent polish

## TYPICAL APPLICATIONS

- General lifting purposes
- Wire rope slings
- General lifting in off-shore applications
- Chemical installations, e.g. chlorine plants, etc.



THIMBLE



WIRE ROPE CLIP (BULLDOG GRIP)

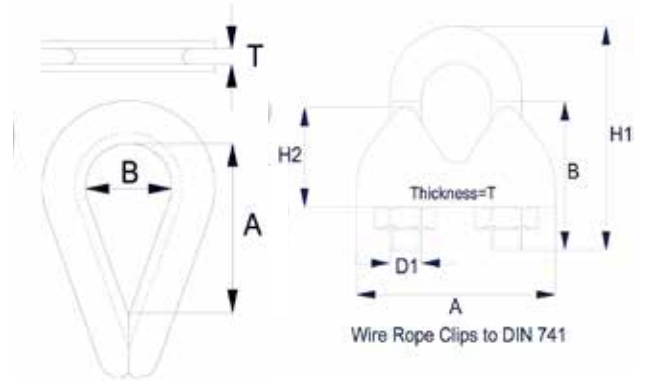

## THIMBLES

Groove width	DIMENSIONS (MM)			ITEM CODES	NOMINAL WEIGHT Per 100 pcs (kg)
	A	B	T		
2	12	8	1.0	THIM-020	0.30
2.5	16	10	1.0	THIM-2.50	0.40
3	16	10	1.0	THIM-030	0.40
4	17	11	1.0	THIM-040	0.50
5	20	13	1.0	THIM-050	0.60
6	25	16	1.2	THIM-060	1.00
7	28	18	1.2	THIM-070	1.20
8	32	20	1.4	THIM-080	1.80
10	40	26	1.6	THIM-100	2.90
12	45	28	2.0	THIM-120	4.60
14	56	34	2.2	THIM-140	9.00
16	62	37	2.5	THIM-160	10.40
18	68	42	2.8	THIM-180	17.10
20	75	46	3.4	THIM-200	27.70
22	85	50	3.6	THIM-220	29.70
24	94	58	4.5	THIM-240	54.90
26	102	66	4.5	THIM-260	60.50

## WIRE ROPE CLIPS (BULLDOG GRIPS) TO DIN 741

Wire rope dia.	DIMENSIONS (MM)						ITEM CODES	NOMINAL WEIGHT Per Item (kg)
	A	B	D1	H1	H2	T		
2	17	11	M3	17.5	10.0	10	CLIPL-02	0.007
3	18	12	M3	21.0	11.0	10	CLIPL-03	0.012
4	21	14	M4	23.0	13.0	11	CLIPL-04	0.014
5	25	15	M5	28.0	15.0	12	CLIPL-05	0.015
6	28	17	M6	32.0	17.0	16	CLIPL-06	0.021
8	31	21	M6	36.0	20.0	18	CLIPL-08	0.041
10	36	25	M8	44.0	23.0	19	CLIPL-10	0.068
14	47	28	M10	55.0	25.5	26	CLIPL-14	0.130
16	52	32	M12	65.0	28.0	26	CLIPL-16	0.210
19	58	38	M12	78.0	32.0	30	CLIPL-19	0.280
22	64	40	M12	86.0	43.5	32	CLIPL-22	0.400
25	69	46	M14	94.0	43.5	32	CLIPL-25	0.440

# EN SWAGING FOR LIFTING - THE PETERSEN SWAGING SYSTEM

Swaging is a method of securing wire rope or cable with a permanently applied fitting or sleeve. When properly applied, the swaged connection will exceed the rated breaking strength of the wire rope or cable. BS EN 13411 is the European standard which controls the safety of steel wire-rope terminations; part 8 is the section focused on swaged terminals and swaging.

## A SYSTEM TO DELIVER QUALITY RESULTS CONSISTENTLY

The Petersen Swaging System comprises three elements:

- The methodology, including record-keeping
- A machine for pressing fittings onto wire-rope
- The consumables, i.e. the fittings and wire-rope

It is intended for the production of swaged terminal wire-rope assemblies. The intended end use of the wire-rope accessory, such as a sling, or wire-rope assembly is to perform a raising, lowering, holding or supporting function on lifting machinery, taking into account the national provisions of the Member State applicable for the location where the product will be in use.

## A TRIED AND TESTED METHODOLOGY

To conform to BS EN 13411-8, an assembly of wire-rope and swaged termination must provide at least 90% of the wire-rope's minimum breaking load (MBL) after 75,000 cycles of use.

The Institut für Fördertechnik und Logistik (Institute for Material Handling and Logistics) at the University of Stuttgart performed cyclic load tests and tensile tests on wire-ropes fitted with stud terminals installed using the Petersen Swaging System. The samples were tested using a force between 15% and 30% of the Minimum Breaking Load (MBL) of the wire-rope. After the cyclic load tests, a break load test was completed to determine the residual breaking strength.

All tests were conducted according to EN 13411-8. All test samples achieved the required 75,000 cycles in the cyclic load test, and in the subsequent break test all test samples achieved more than the required 80% of the MBL of the wire-rope.

Comparing the break loads after the cyclic test with the actual break loads, it was shown that the cyclic load had no further influence on the break load.

## AN APPROVED MACHINE AND ACCESSORIES

The swaging machines we use in-house, and recommend for use if compliance with the Petersen system is required, are Wiretechnik Roller Swaging Machines. Petersen offers a range of swaging machines from Wiretechnik to suit different types of needs, together with dies, pumps and pulling tools. See data below for technical data for swage machine sizes, or speak to our team for more details:

	P200		P350		P400	
	Metric	Imperial	Metric	Imperial	Metric	Imperial
Range of swages possible	1.6 – 8 mm	1/16" – 5/16"	2.5 – 16 mm	3/32" – 5/8"	8 – 28 mm	5/16" – 1 1/8"
Length	500 mm	19.75"	1117 mm	44.00"	990 mm	39.00"
Width	300 mm	11.75"	370 mm	14.75"	530 mm	20.86"
Height	140 mm	5.50"	210 mm	8.25"	370 mm	14.50"
Weight	19.5 kg	42 lb	66 kg	146 lb	142 kg	313 lb

## QUALITY EN TERMINALS

All swage terminals are supplied with instructions for the correct fitting and safe usage. Raw material certificates are also available on request, providing full traceability for all our items.

# EN SWAGING FOR LIFTING - THE PETERSEN SWAGING SYSTEM

## THE PETERSEN COMBINED SWAGE & TEST MACHINE

We have worked with Wireteknik to develop a combined swage and test machine, bringing two functions together in one patented machine. The swaging function uses an hydraulic cylinder to pull the socket between two roller dies, pressing it onto the cable as per all Wireteknik machines. After swaging, the cable can be gripped with the integrated non-marking wire-rope grips and a proof load applied to test the integrity of the termination.

The machines can be supplied with either a calibrated pressure gauge or a load-cell to measure the proof-load. The compact size and comparatively low weight of the Petersen Combined Swage & Test machines means they can easily be loaded onto a truck for on-site fabrication and repairs of wire rope slings and crane ropes. The hydraulics can be operated by the means of a hand pump (more suited to the smaller machines) or a single or 3-phase electric pump.

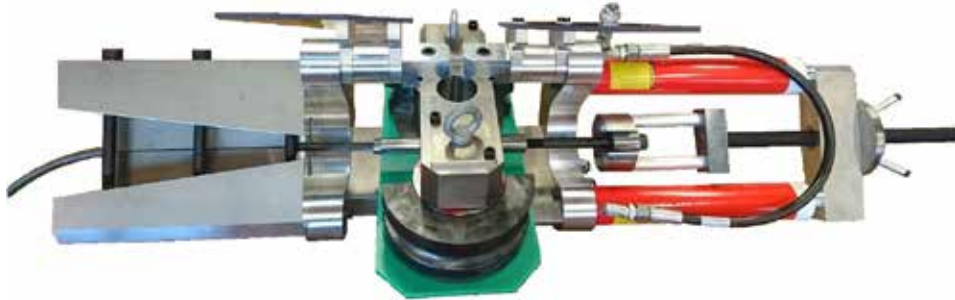

*The Petersen P400 Combined Swage & Test Machine*

## SWAGING DIMENSIONS

The swager is designed to reduce the terminal shank to the required diameter in one pass. See below our recommended swaging dimensions:

Wire Ø		Terminal hole depth		Pre-swage Ø		Post-swage Ø	
MM	Inches	MM	Inches	MM	Inches	MM	Inches
1.6	-	15	0.591	4.06/3.94	0.160/0.155	3.50/3.40	0.138/0.134
2.5	-	26		5.53/5.41	0.217/0.213	4.82/4.7	0.190/0.185
3	1/8	39	1.535	6.35/6.22	0.250/0.245	5.56/5.44	0.219/0.214
4	5/32	45	1.772	7.54/7.42	0.297/0.292	6.35/6.23	0.250/0.245
5	3/16	52	2.047	9.12/9.00	0.359/0.354	7.95/7.83	0.313/0.308
5.5	7/32	56	2.205	10.84/10.72	0.427/0.422	9.50/9.35	0.374/0.368
6	1/4	64	2.520	12.54/12.42	0.494/0.489	11.12/10.95	0.437/0.431
7	9/32	70	2.756	14.30/14.18	0.563/0.558	12.70/12.50	0.500/0.492
8	5/16	80	3.150	16.13/16.01	0.642/0.630	14.30/14.07	0.563/0.554
9-10	3/8	100	3.937	17.85/17.73	0.703/0.698	15.90/15.70	0.626/0.618
11	7/16	121	4.764	19.83/19.63	0.781/0.773	17.47/17.27	0.688/0.680
12	1/2	132	5.197	21.44/21.32	0.844/0.839	19.05/18.82	0.750/0.741
14	9/16	156	6.142	25.00/24.88	0.984/0.979	22.23/22.00	0.875/0.866
16	5/8	176	6.930	28.17/28.05	1.109/1.104	25.40/25.15	1.000/0.990
18	-	200	7.874	34.52/34.40	1.359/1.354	31.75/31.44	1.250/1.238
19-20	3/4	210	8.268	34.52/34.40	1.359/1.354	31.75/31.44	1.250/1.238
22	7/8	242	9.528	40.46/40.21	1.593/1.583	36.50/36.20	1.437/1.425
24	-	264	10.394	46.02/45.77	1.812/1.802	41.28/40.97	1.625/1.613
25-26	1	290	11.417	46.02/45.77	1.812/1.802	41.28/40.97	1.625/1.613
28	-	312	12.284	50.0	1.969	44/44.5	1.732/1.752
32	-	335	13.189	58.0	2.283	51/51.5	2.007/2.027

# EN STAINLESS STEEL SWAGE TERMINATIONS

## PRODUCT FEATURES

Manufactured from 316L stainless steel (1.4404)

Available for standard wires sizes from 3mm up to 32mm; please contact us direct for the correct part codes for swage terminals for imperial wire sizes. Other sizes and custom lengths on request

Excellent grain structure - resists corrosion and fatigue

All supplied with instruction leaflet on safe use and storage

Factor of Safety 6:1

## QUALITY FEATURES

Manufactured in accordance with the Machine Directive 2006/42/EC

Inspection certificate BS EN 10204 3.1 provided as standard

High quality finish and excellent polish

No casting or welding

Fatigue rated in accordance with EN 13411-8

Each termination is individually engraved with the test batch reference

## TYPICAL APPLICATIONS

General lifting, including for off-shore applications

General lifting and tethering in leisure marine applications - not submerged

## STAINLESS STEEL SWAGE STUDS

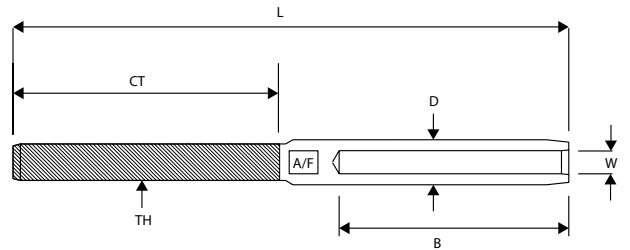

Wire (W) (mm)	DIMENSIONS (MM)						WLL (KG)		ITEM CODES
	TH	D	B	L	CT	A/F	7X19 / 6X19- IWRC	6X36-IWRC	
3	M6	6.3	39.0	97.0	47.0	5.0	70	-	SCM6X3-EN
4	M6	7.5	45.0	105.0	47.0	6.0	125	-	SCM6X4-EN
4	M8	7.5	45.0	113.0	54.0	6.0	125	-	SCM8X4-EN
5	M8	9.1	52.0	122.0	54.0	8.0	200	-	SCM8X5-EN
5	M10	9.1	52.0	135.0	64.0	8.0	200	-	SCM10X5-EN
6	M10	12.5	65.0	154.0	75.0	11.0	285	300	SCM10X6-EN
6	M12	12.5	65.0	170.0	90.0	11.0	285	300	SCM12X6-EN
7	M12	14.3	70.0	177.0	90.0	12.0	390	-	SCM12X7-EN
8	M12	16.0	80.0	190.0	90.0	14.0	510	545	SCM12X8-EN
8	M16	16.0	80.0	201.0	100.0	14.0	510	545	SCM16X8-EN
10	M16	18.0	100.0	223.0	100.0	16.0	795	855	SCM16X10-EN
12	M20	21.4	132.0	277.0	120.0	19.0	1150	1230	SCM20X12-EN
14	M22	25.0	156.0	325.0	140.0	22.0	1515	1675	SCM22X14-EN
16	M27	28.2	176.0	371.0	160.0	25.0	2040	2175	SCM27X16-EN
19	M30	34.5	210.0	427.0	184.0	30.0	-	-	SCM30X19-EN
22	M36	40.3	242.0	482.0	202.0	32.0	-	4125	SCM36X22-EN
26	M42	45.9	290.0	557.0	223.0	36.0	-	5415	SCM42X26-EN

Please note, components are available with left or right hand threads as well as UNF threads. Sizes above 26mm are available on request.

# EN STAINLESS STEEL SWAGE TERMINATIONS

## STAINLESS STEEL SWAGE EYES / CLOSED SOCKETS

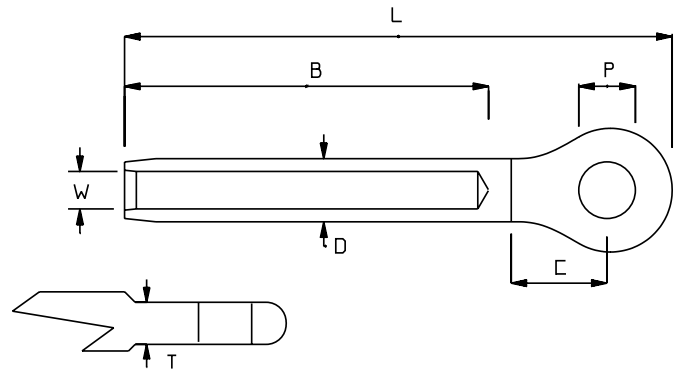

Wire (W) (mm)	DIMENSIONS (MM)						WLL (KG)		ITEM CODES
	P	B	D	C	T	L	7X19 / 6X19- IWRC	6X36-IWRC	
3	6.5	39	6.3	11	5	60	70	-	SE03-EN
4	8.2	45	7.5	14	6.5	72	125	-	SE04-EN
5	9.7	52	9.1	17	7.8	85	200	-	SE05-EN
6	11.1	64	12.5	23	11.5	110	285	300	SE06-EN
7	12.7	70	14.3	23	11.5	114	390	-	SE07-EN
8	12.7	80	16	23	11.5	125	510	545	SE08DS-EN
8	14.3	80	16	24	13.5	130	510	545	SE08-EN
8	16	80	16	29	15	134	510	545	SE08US-EN
10	16	100	18	29	15	155	795	855	SE10-EN
12	19.1	132	21.4	34	17.5	197	1150	1230	SE12-EN
14	22.2	156	25	40	21.5	235	1515	1675	SE14-EN
16	28.6	176	28.2	51	27	274	2040	2175	SE16-EN
19	28.6	210	34.5	51	27.5	308	-	-	SE19-EN
22	32	242	40.3	58	31	356	-	4125	SE22-EN
26	35	290	45.9	63	33.5	414	-	5415	SE26-EN

Sizes above 26mm are available on request.

## STAINLESS STEEL SWAGE SHACKLE TOGGLE



Also available with an E-pin

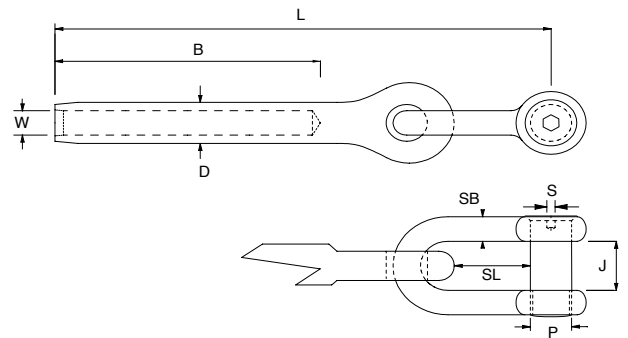

Wire (W)	DIMENSIONS (MM)								WLL (KG)		ITEM CODES
	P	D	B	SB	SL	S	J	L	7X19 / 6X19- IWRC	6X36-IWRC	
3	6.0	6.3	39.0	5.0	14.0	3.0	14.0	82	70	-	SST03-EN
4	8.0	7.5	45.0	6.0	16.0	4.0	20.0	101	125	-	SST04-EN
5	9.5	9.1	52.0	8.0	22.0	4.0	22.0	118	200	-	SST05-EN
6	11.0	12.7	64.0	9.5	27.0	5.0	25.0	141	285	300	SST06-EN
7	12.7	14.3	71.0	11.0	32.0	5.0	27.0	158	390	-	SST07-EN
8	14.0	16.0	80.0	12.7	36.0	5.0	29.0	179	510	545	SST08-EN
10	16.0	18.0	100.0	14.3	42.0	6.0	29.0	216	795	855	SST10-EN
12	19.0	21.4	132.0	16.0	45.0	6.0	32.0	263	1150	1230	SST12-EN
14	22.0	25.0	156.0	19.0	63.0	8.0	38.0	309	1515	1675	SST14-EN
16	25.4	28.2	176.0	22.0	63.0	8.0	45.0	351	2040	2175	SST16-EN

Please note, for E Pin shackles, please place an 'E' into the item code, e.g SST10E-EN

# EN STAINLESS STEEL SWAGE TERMINATIONS

## STAINLESS STEEL SWAGE OPEN SOCKETS

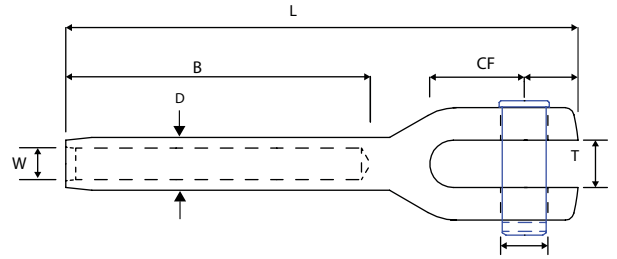

Wire (W) (mm)	DIMENSIONS (MM)						WLL (KG)		ITEM CODES
	P	D	CF	T	B	L	7X19 / 6X19- IWRC	6X36-IWRC	
3	6.0	6.3	12.5	6.2	39.0	70.0	70	-	SF03-EN
4	8.0	7.5	17.0	7.9	45.0	83.0	125	-	SF04-EN
5	9.5	9.1	19.0	9.9	52.0	97.0	200	-	SF05-EN
6	11.0	12.5	22.0	10.9	64.0	113.0	285	300	SF06-EN
7	12.0	14.3	25.0	12.7	70.0	128.0	390	-	SF07-EN
8	12.0	16.0	25.0	12.7	80.0	140.0	510	545	SF08DS-EN
8	14.0	16.0	28.0	13.8	80.0	144.5	510	545	SF08-EN
10	16.0	18.0	32.0	15.8	100.0	174.0	795	855	SF10-EN
12	19.0	21.4	38.0	17.8	132.0	227.0	1150	1230	SF12-EN
14	22.0	25.0	45.0	22.0	156.0	258.0	1515	1675	SF14-EN
16	25.0	28.2	50.0	25.0	176.0	295.5	2040	2175	SF16-EN
19	28.0	34.5	58.0	28.2	210.0	342.0	-	-	SF19-EN
22	32.0	40.3	64.0	31.8	242.0	391.0	-	4125	SF22-EN
26	35.0	45.9	70.0	34.8	290.0	451.5	-	5415	SF26-EN

Sizes above 26mm are available on request.

### WHY CHOOSE AN EN SWAGE FITTING?

BS EN 13411 is the European standard which controls the safety of steel wire-rope terminations. Part 8 is the section focussed on swaged terminals and swaging. To conform to the standard, the assembly of wire-rope and swaged termination must provide at least 90% of the wire-rope's minimum breaking load (MBL) after 75,000 cycles of use.

Swages produced using the Petersen method have been independently tested against BS EN 13411-8 and all passed both the cyclic load and tensile tests.

This means that by choosing an EN swage termination, and fitting it in accordance with the Petersen Swaging System, the final assembly can be CE marked.



# BLAYDON BLOCKS (INDUSTRIAL LIFTING BLOCKS)

## PRODUCT FEATURES

Manufactured from stainless steel EN10088 1.4404 (Marine Grade 316L) and Tufnol

Excellent for lifting applications where a high level of corrosion resistance is required

Factor of Safety 6:1

All sizes are of a bolted construction and can simply be dismantled for replacement of sheaves or general maintenance

All blocks CE marked and supplied with instruction leaflet on safe use and storage

## QUALITY FEATURES

Proof load tested to 2 x WLL and certified at our UK manufacturing

All blocks are manufactured in accordance with the Machine Directive 2006/42/EC

Inspection certificate BS EN 10204 3.1 provided as standard

High quality finish and excellent polish

## TYPICAL APPLICATIONS

General lifting purposes

High towers and lines where weight carried is of prime importance

Double blocks are used in pairs by electricity boards for live line working

General lifting in off-shore applications



DOUBLE



SINGLE



BLOCK FITTING



SHEAVES



SINGLE VIEW



EYE DIMENSION

DIMENSIONS (MM) & WLL (KG)									BLOCK STYLE & ITEM CODE			NOMINAL WEIGHT per block (kg)		
Block Size	Max. Rope Dia.	Max. Rope Circumf.	Sheave Dia.	Sheave Width	Eye Width (EW)	Eye Length (EL)	WLL	Suggested Shackles	Single	Double	Triple	Single	Double	Triple
4	16.0	50.0	83.0	19.0	17.0	34.0	1000	ED12M12	BBSE4	BBDE4	BBTE4	1.06	1.50	1.80
6	19.0	62.0	95.0	22.0	20.0	40.0	1500	ED14M16	BBSE6	BBDE6	BBTE6	1.90	2.40	2.90
12	25.0	74.0	121.0	30.0	28.0	50.0	2800	ED16M20	BBSE12	BBDE12	BBTE12	4.80	5.70	9.10
14	32.0	103.0	144.0	36.0	30.0	60.0	3500	ED22M24	BBSE14	BBDE14	BBTE14	6.80	7.67	12.25

# CERTIFICATION

## SAMPLES OF OUR TEST AND INSPECTION CERTIFICATES

We test all lifting shackles and turnbuckles to proof load at our factory before despatch. We also manufacture all lifting shackles and equipment in accordance with the 2006/42/EC Machine Directive. This allows us to stamp each product with a CE mark.

We have detailed below a sample of certificates available with all lifting shackles and equipment.

**Original instructions for the safe use of Petersen HI-MOD PH Dee and Bow Shackles**  
Pin Type A, AL, B.

In Accordance with the 2006/42/EC Machine Directive & The Supply of Machinery (Safety) Regulations 2008 (SI 2008/1997)

The information in this leaflet should be passed to the user of the equipment

**Introduction**  
All Petersen HI-MOD PH Shackles have been manufactured and tested in accordance with the applicable test guidelines issued under Lifting Operations and Lifting Equipment Regulations 1998 (LOLER) and The Supply of Machinery (Safety) Regulations 2008 (SI 2008/1997).

Petersen PH shackles are manufactured from 1314 stainless steel and are proof tested to their Working Load Limit (WLL) using equipment certified to BS EN 10002-2 and tested to BS EN 10004. The test temperature was 23 ± 2 °C.

**Design & Application**  
All Petersen PH shackles have a specific design for a specific application. The Petersen PH shackle range is designed and manufactured for general lifting applications. The Petersen PH shackles are not to be used for lifting people or used on other equipment to lift people.

**Manufacturer and Place of Manufacture**  
The Petersen PH shackles are manufactured by Petersen Stainless Rigging Limited at their production facility located at Queen Place, Blaydon on Tyne, Tyne & Wear, NE21 5TW United Kingdom.

**Product Information & Description**  
Petersen PH shackles are made from PH 1314, a stainless steel, offering high strength and corrosion resistance with excellent corrosion resistance. PH shackles are heat treated to achieve a minimum tensile strength of 1030 MPa (147,000 psi) and a minimum yield strength of 550 MPa (78,750 psi) for all shackles. The minimum tensile strength of the shackles is 1030 MPa (147,000 psi) and the minimum yield strength is 550 MPa (78,750 psi).

**Assembly**  
The pin and shackle body will come together easily and should be fully seated. Do not use any threading grease or other such products which may affect or hold either parts of the pin or shackle.

**Do not use the shackle if the pin does not screw fully into place. Please refer to the 'How to Load' diagrams for a description of correct assembly.**

**Instructions for use**  
Shackles should be inspected before use to ensure that:  
• all markings are legible;  
• the threads of the pin and the body are unobstructed;  
• there are no visible signs of fatigue or damage to the shackle body or pin;  
• the body and pin are not distorted or unduly worn;  
• shackles may not be heat treated as this may affect their working load limit;  
• never modify, repair or replace a shackle as this will affect its Working Load Limit.

**Storing and Handling Shackles**  
Never return damaged shackles to storage. They should be inspected and repaired before reuse. Do not use other shackles or repair shackles and never replace missing pins, bolts etc., but refer each matter to a competent person. Never substitute or subject to other plating processes without the manufacturer's agreement.

INSTRUCTION AND GUIDANCE 2006/42/EC

**Original instructions for the safe use of Petersen HI-MOD PH Dee and Bow Shackles**  
Pin Type A, AL, B.

In Accordance with the 2006/42/EC Machine Directive & The Supply of Machinery (Safety) Regulations 2008 (SI 2008/1997)

The information in this leaflet should be passed to the user of the equipment

**Inspection of shackles.**  
Before the shackle is first put into use it should be examined for signs of damage.  
If it is found, or suspected, that the shackle has been subjected to an excess load or the shackle shows any sign of cracking, splitting or deformation it must be destroyed.  
It is required that the shackles are regularly inspected and that the inspection should take place in accordance with the safety standards given in the country of use. This is required because the shackles in use may be affected by stress, fatigue, overloading etc. with a consequence of deformation and alteration of the material structure. Inspection should take place at least every 6 months and more frequently when the shackles are used in severe operating conditions.

**How to Load**  
Fig 2

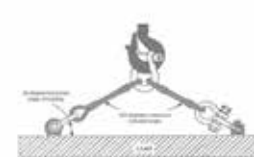

**Fig 1**  
Check for wear tracks on the shackle body. Check the body for distortion. Check for wear on the shackle pin. Ensure the shackle pin is fully engaged. When a shackle pin is fully engaged, there is a security and lock.

Dimension	Pin Diameter	Shackle Thickness
1	12.0	1.5
2	16.0	2.0
3	20.0	2.5
4	24.0	3.0
5	28.0	3.5
6	32.0	4.0

**Product marking**  
Fig 3

WLL: Working Load Limit in tonnes  
PH: material specification  
AS: test batch reference number  
CE: Conformity code

**WARNING**  
Shackles should always be used in line with good rigging practice and as per the manufacturer's instructions. Incorrect shackle use could result in a dangerous situation that could cause property damage, personal injury or death.

**Good Rigging Practices**  
• The shackle pin must be fully engaged, with the head of the pin in contact with the shackle body.  
• If a shackle is designed for a collar pin, any replacement collar pins must meet or exceed the original manufacturer's specifications.  
• Contact with sharp edges which could damage the shackle should be avoided.  
• Shock loading should be avoided.  
• The load applied to the shackle should be indicated in the line of the shackle to prevent side loading of the shackle.  
• Multiple sling legs should not be applied to the shackle pin.  
• If the shackle is to be side loaded, the load must be reduced according to the recommendations of the manufacturer or qualified person (see Fig 3).

INSTRUCTION AND GUIDANCE 2006/42/EC

**Certificate of Test and Examination**  
EN10204 3.1

Health and Safety Executive  
Statutory Instruments 1998 No. 2307  
The Lifting Operations and Lifting Equipment Regulations 1998

Certificate Number: 13278      Certificate Date: 31/07/2019

**Identification Mark of Equipment:** 546292A

**Date of Manufacture:** 22 Mar 2018

**Product Code of Item Tested & Examined:** RSPF08 WLL

**Description of Item Tested & Examined:** 5/8" (3) FF Rig Screw WLL 1325 kgs

**Quantity Tested and Examined:** 1

**Date of Test and Examination:** 31/07/2019

**Proof Load Applied During Test:** 1753kg

**Working Load Limit Assessed:** 1325kg

**Product WIP Number:** 546292A

**Notes on Test:**

**Name of Person making the declaration on behalf of the company:** Shelley Wain  
Petersen Stainless Rigging Limited  
Coar Road  
Blaydon on Tyne  
TYNE AND WEAR  
NE21 5TW  
GREAT BRITAIN

**Name and Address of Owner of Equipment:** Towers Lifting & Testing (Head Office)  
Wylthine Road  
Capricornia Industrial Estate  
Hull  
HU4 6PA  
GREAT BRITAIN

**DECLARATION**  
I hereby declare that the item described on this record was tested and examined in accordance with the applicable provisions and it is found free from any defect likely to affect safety on the date detailed.

Signature: *Shelley Wain*      Date: *31/07/2019*

EN10204 3.1

CERTIFICATE OF TEST AND EXAMINATION

**DECLARATION OF CONFORMITY**

The equipment which accompanies this declaration is in conformity with EU Directive 2006/42/EC Machine Directive & The Supply of Machinery (Safety) Regulations 2008 (SI 2008/1997).

This declaration relates exclusively to the equipment in the state in which it was placed on the market, and excludes components which are added and/or operations carried out subsequently by the final user.

**MANUFACTURER AND EQUIPMENT DETAILS**

**Manufacturer:** Petersen Stainless Rigging Limited  
Queen Road  
Blaydon on Tyne  
TYNE AND WEAR  
NE21 5TW  
GREAT BRITAIN

**Product Code:** RSPF08 WLL

**Product Batch Reference:** 44292A

**Product Description:** 5/8" (3) FF Rig Screw WLL 1325 kgs

**WLL Test Certificate Number:** 13278

**Batch Reference of Proof Test:** 546292A

**Manufactured Date:** 22 Mar 2018

A copy of the Technical File for this equipment is available from Petersen Stainless Rigging Tyne & Wear, NE21 5TW, United Kingdom.

I confirm that the details above comply with the requirements of the Machine Directive set out above.

**Name:** KEVIN BELL  
**Position in Company:** Director

**Place and Date:** Blaydon on Tyne, UK      02/10/2019

DECLARATION OF CONFORMITY

# TERMS & CONDITIONS

## 1. Interpretation

1.1 In these Conditions "BUYER" means the person who accepts a quotation of the Seller for the sale of the Goods or whose order for the Goods is accepted by the Seller "GOODS" means the goods (including any instalment of the goods or any parts for them) which the Seller is to supply in accordance with these Conditions "SELLER" means PETERSEN STAINLESS RIGGING LIMITED [or any associated or subsidiary company of it] "CONDITIONS" means the standard terms and conditions of sale set out in this document and (unless the context otherwise requires) includes any special terms and conditions agreed in writing between the Buyer and the Seller "CONTRACT" means the contract for the purchase and sale of the Goods "WRITING" includes telex, cable, facsimile transmission and comparable means of communication

1.2 Any reference in these Conditions to any provision of a statute shall be construed as a reference to that provision as amended, re-enacted or extended at the relevant time.

## 2. Basis of the Sale

2.1 The Seller shall sell and the Buyer shall purchase the Goods in accordance with any written quotation of the Seller which is accepted by the Buyer, or any order of the Buyer which is accepted by the Seller, subject in either case to these Conditions, which shall govern the Contract to the exclusion of any other terms and conditions subject to which any such quotation is accepted or purported to be accepted, or any such order is made or purported to be made, by the Buyer.

## 3. Orders and Specifications

3.1 No order submitted by the Buyer shall be deemed to be accepted by the Seller unless and until confirmed in Writing by the Seller's authorised representative.

3.2 The Buyer shall be responsible to the Seller for ensuring the accuracy of the terms of any order (including any applicable specification) submitted by the Buyer, and for giving the Seller any necessary information relating to the Goods within a sufficient time to enable the Seller to perform the Contract in accordance with its terms.

3.3 The quantity, quality and description of and any specification for the Goods shall be those set out in the Seller's quotation (if accepted by the Buyer) or the Buyer's order (if accepted by the Seller).

3.4 If the Goods are to be manufactured or any process is to be applied to the Goods by the Seller in accordance with a specification submitted by the Buyer, the Buyer shall indemnify the Seller against all loss, damages, costs and expenses awarded against or incurred by the Seller in connection with or paid or agreed to be paid by the Seller in settlement of any claim for infringement of any patent, copyright, design, trade mark or other industrial or intellectual property rights of any other person which results from the Seller's use of the Buyer's specification.

3.5 The Seller reserves the right to make any changes in the specification of the Goods which are required to conform with any applicable statutory requirements or EC requirements or, where the Goods are to be supplied to the Seller's specification, which do not materially affect their quality or performance.

3.6 No order which has been accepted by the Seller may be cancelled by the Buyer except with the agreement in Writing of the Seller and on terms that the Buyer shall indemnify the Seller in full against all loss (including loss of profit), costs (including the cost of all labour and materials used), damages, charges and expenses incurred by the Seller as a result of cancellation.

## 4. Price of the Goods

4.1 The price of the Goods shall be the Seller's quoted price or, where no price has been quoted (or a quoted price is no longer valid), the price listed in the Seller's published price list current at the date of despatch of the order. Where the goods are for export from the United Kingdom, the Seller's published export price list shall apply. All prices quoted are valid for 30 days only or until earlier acceptance by the Buyer, after which time they may be altered by the Seller without giving notice to the Buyer.

4.2 The Seller reserves the right, by giving notice to the Buyer at any time before delivery, to increase the price of the Goods to reflect any increase in the cost to the Seller which is due to any factor beyond the control of the Seller (such as, without limitation, any foreign exchange fluctuation, currency regulation, alteration of duties, significant increase in the costs of labour, materials or other costs of manufacture), any change in delivery date, quantities or specifications for the Goods which is requested by the Buyer, or any delay caused by any instructions of the Buyer or failure of the Buyer to give the Seller adequate information or instructions.

4.3 Except as otherwise stated under the terms of any quotation or in any price list of the Seller, and unless otherwise agreed in Writing between the Buyer and the Seller, all prices are given by the Seller on a delivered basis, but where the Seller agrees to deliver the Goods otherwise than at the Seller's premises, the Buyer shall be liable to pay the Seller's additional charges for transport, packaging and insurance.

4.4 The price is exclusive of any applicable value added tax, which the Buyer shall be additionally liable to pay to the Seller at the prevailing rate applicable at the time of despatch of the goods.

## 5. Terms of Payment

5.1 Subject to any special terms agreed in Writing between the Buyer and the Seller, the Seller shall be entitled to invoice the Buyer for the price of the Goods on or at any time after delivery of the Goods, unless the Goods are to be collected by the Buyer or the Buyer wrongfully fails to take delivery of the Goods, in which event the Seller shall be entitled to invoice the Buyer for the price at any time after the Seller has notified the Buyer that the Goods are ready for collection or (as the case may be) the Seller has tendered delivery of the Goods.

5.2 The Buyer shall pay the price of the Goods within [30 days] of the date of the Seller's invoice, notwithstanding that delivery may not have taken place and the property in the Goods has not passed to the Buyer. The time of payment of the price shall be of the essence of the Contract. Receipts for payment will be issued only upon request.

5.3 If the Buyer fails to make any payment on the due date then, without prejudice to any other right or remedy available to the Seller, the Seller shall be entitled to cancel the contract or suspend any further deliveries to the Buyer, and charge the Buyer interest (both before and after any judgment) on the amount unpaid, at the rate of 3 per cent per annum above the base rate of Barclays Bank plc from time to time, until payment in full is made (a part of a month being treated as a full month for the purpose of calculating interest).

5.4 Where delivery is made by instalments each separate delivery shall constitute a separate order for the purposes of payment

## 6. Delivery

6.1 Any dates quoted for delivery of the Goods are approximate only and the Seller shall not be liable for any delay in delivery of the Goods howsoever caused. Time for delivery shall not be of the essence unless previously agreed by the Seller in writing. The Goods or any part of them may be delivered by the Seller in advance of the quoted delivery date upon giving reasonable notice to the Buyer.

6.2 Where the Goods are to be delivered in instalments, each delivery shall constitute a separate contract and failure by the Seller to deliver any one or more of the instalments in accordance with these Conditions or any claim by the Buyer in respect of any one or more instalments shall not entitle the Buyer to treat the Contract as a whole as repudiated.

6.3 If the Seller fails to deliver the Goods for any reason other than any cause beyond the Seller's reasonable control or the Buyer's fault, the Buyer shall give written notice to the Seller within 7 days of the expected date of delivery and the Seller's liability shall be limited to the excess (if any) of the cost to the Buyer (in the cheapest available market) of similar goods to replace those not delivered over the price of the Goods.

6.4 If the Buyer fails to take delivery of the Goods or fails to give the Seller adequate delivery instructions at the time stated for delivery (otherwise than by reason of any cause beyond the Buyer's reasonable control or by reason of the Seller's fault) then, without prejudice to any other right or remedy available to the Seller, the Seller may store the Goods until actual delivery and charge the Buyer for the reasonable costs (including insurance) of the storage; or sell the Goods at the best price readily obtainable and (after deducting all reasonable storage and selling expenses) charge the Buyer for any shortfall below the price under the Contract.

## 7. Risk and Property

7.1 Risk of damage to or loss of the Goods shall pass to the Buyer:

7.1.1 in the case of Goods to be delivered otherwise than at the Buyer's premises at the time when the Seller notifies the Buyer that the Goods are available for collection; or

7.1.2 in the case of Goods to be delivered at the Buyer's premises, at the time of delivery or, if the Buyer wrongfully fails to take delivery of the Goods, the time when the Seller has tendered delivery of the Goods.

7.2 Notwithstanding delivery and the passing of risk in the Goods, or any other provision of these Conditions, the property in the Goods shall not pass to the Buyer until the Seller has received in cash or cleared funds payment in full of the price of the Goods and all other goods agreed to be sold by the Seller to the Buyer and previously invoiced whether or not actually delivered.

7.3 Until such time as the property in the Goods passes to the Buyer, the Buyer shall hold the Goods as the Seller's fiduciary agent and bailee, and shall keep the Goods separate from those of the Buyer and third parties and properly stored, protected and insured and identified as the Seller's property, but shall be entitled to re-sell or use the Goods in the ordinary course of its business.

7.4 Until such time as the property in the Goods passes to the Buyer (and provided the Goods are still in existence and have not been resold), the Seller shall be entitled at any time to require the Buyer to deliver up the Goods to the Seller and, if the Buyer fails to do so forthwith, to enter upon any premises of the Buyer or any third party where the Goods are stored and repossess the Goods.

7.5 The Buyer shall not be entitled to pledge or in any way charge by way of security for any indebtedness any of the Goods which remain the property of the Seller, but if the Buyer does so all moneys owing by the Buyer to the Seller shall (without prejudice to any other right or remedy of the Seller) forthwith become due and payable.

## 8. Warranties and Liability

8.1 Subject to the conditions set out below the Seller warrants that the Goods will correspond with their specification at the time of delivery which specifications shall be determined by the terms of the Contract and not by any drawings, photographs, illustrations or other descriptive matter accompanying the Seller's estimates or contained in any advertising matter.

8.2.1 the Seller shall be under no liability in respect of any defect in the Goods arising from any drawing, design or specification supplied by the Buyer;

8.2.2 the Seller shall be under no liability in respect of any defect arising from fair wear and tear, wilful damage, negligence, abnormal working conditions, failure to follow the Seller's instructions (whether oral or in writing) misuse or alteration or repair of the Goods without the Seller's approval;

8.2.3 the Seller shall be under no liability under the above warranty (or any other warranty, condition or guarantee) if the total price for the Goods has not been paid by the due date for payment;

8.2.4 the above warranty does not extend to parts, materials or equipment not manufactured by the Seller, in respect of which the Buyer shall only be entitled to the benefit of any such warranty or guarantee as is given by the manufacturer to the Seller.

8.3 Subject as expressly provided in these Conditions, and except where the Goods are sold to a person dealing as a consumer (within the meaning of the Unfair Contract Terms Act 1977), all warranties, conditions or other terms implied by statute or common law are excluded to the fullest extent permitted by law.

8.4 Any claim by the Buyer which is based on any defect in the quality or condition of the Goods or their failure to correspond with specification shall (whether or not delivery is refused by the Buyer) be notified to the Seller within 7 days from the date of delivery. If delivery is not refused, and the Buyer does not notify the Seller accordingly, the Buyer shall not be entitled to reject the Goods and the Seller shall have no liability for such defect or failure, and the Buyer shall be bound to pay the price as if the Goods had been delivered in accordance with the Contract.

8.5 Where any valid claim in respect of any of the Goods which is based on any defect in the quality or condition of the Goods or their failure to meet specification is notified to the Seller in accordance with these Conditions, the Seller shall be entitled to replace the Goods (or the part in question) free of charge or, at the Seller's sole discretion, refund to the Buyer the price of the Goods (or a proportionate part of the price) in respect of which liability arises, but the Seller shall have no further liability to the Buyer.

8.6 Except in respect of death or personal injury caused by the Seller's negligence, the Seller shall not be liable to the Buyer by reason of any representation, or any implied warranty, condition or other term, or any duty at common law, or under the express terms of the Contract, for any consequential loss or damage (whether for loss of profit or otherwise), costs, expenses or other claims for consequential whatsoever (and whether caused by the negligence of the Seller, its employees or agents or otherwise) which arise out of or in connection with the supply of the Goods or their use or resale by the Buyer, and the entire liability of the Seller under or in connection with the Contract shall not exceed the price of the Goods, except as expressly provided in these Conditions.

8.7 The Seller shall not be liable to the Buyer or be deemed to be in breach of the Contract by reason of any delay in performing, or any failure to perform, any of the Seller's obligations in relation to the Goods, if the delay or failure was due to any cause beyond the Seller's reasonable control. Without prejudice to the generality of the foregoing, the following shall be regarded as causes beyond the Seller's reasonable control:

8.7.1 Act of God, explosion, flood, tempest, fire or accident;

8.7.2 war or threat of war, sabotage, insurrection, civil disturbance or requisition;

8.7.3 acts, restrictions, regulations, by-laws, prohibitions or measures of any kind on the part of any governmental, parliamentary or local authority;

8.7.4 import or export regulations or embargoes;

8.7.5 strikes, lock-outs or other industrial actions or trade disputes (whether involving employees of the Seller or of a third party);

8.7.6 difficulties in obtaining raw materials, labour, fuel, parts or machinery;

8.7.7 power failure or breakdown in machinery.

## 9. Insolvency of Buyer

9.1 This clause applies if:

9.1.1 the Buyer makes any voluntary arrangement with its creditors or becomes subject to an administration order or (being an individual or firm) becomes bankrupt or (being a company) goes into liquidation (otherwise than for the purposes of amalgamation or reconstruction); or

9.1.2 an encumbrancer takes possession, or a receiver is appointed, of any of the property or assets of the Buyer; or

9.1.3 the Buyer ceases, or threatens to cease, to carry on business; or

9.1.4 the Seller reasonably apprehends that any of the events mentioned above is about to occur in relation to the Buyer and notifies the Buyer accordingly.

9.2 If this clause applies then, without prejudice to any other right or remedy available to the Seller, the Seller shall be entitled to cancel the Contract or suspend any further deliveries under the Contract without any liability to the Buyer, and if the Goods have been delivered but not paid for the price shall become immediately due and payable notwithstanding any previous agreement or arrangement to the contrary.

## 10. Export Terms

10.1 In these Conditions "Incoterms" means the international rules for the interpretation of trade terms of the International Chamber of Commerce as in force at the date when the Contract is made. Unless the context otherwise requires, any term or expression which is defined in or given a particular meaning by the provisions of Incoterms shall have the same meaning in these Conditions, but if there is any conflict between the provisions of Incoterms and these Conditions, the latter shall prevail.

10.2 Where the Goods are supplied for export from the United Kingdom, the provisions of this clause 11 shall (subject to any special terms agreed in writing between the Buyer and the Seller) apply notwithstanding any other provision of these Conditions.

10.3 The Buyer shall be responsible for complying with any legislation or regulations governing the importation of the Goods into the country of destination and for the payment of any duties thereon.

10.4 Unless otherwise agreed in writing between the Buyer and the Seller, Goods shall be delivered to the air or sea port of shipment and the Seller shall be under no obligation to give notice under section 32(3) of the Sale of Goods Act 1979.

10.5 Payment of all amounts due to the Seller shall be made by irrevocable letter of credit opened by the Buyer in favour of the Seller and confirmed by a bank in England acceptable to the Seller or, if the Seller has agreed in Writing on or before acceptance of the Buyer's order to waive this requirement, by acceptance by the Buyer and delivery to the Seller of a current account cheque in sterling drawn on a Bank in England within 30 days of the invoice date.

## 11. General

11.1 Any notice required or permitted to be given by either party to the other under these Conditions shall be in Writing addressed to that other party at its registered office or principal place of business or such other address as may at the relevant time have been notified pursuant to this provision to the party giving the notice.

11.2 No waiver by the Seller of any breach of the Contract by the Buyer shall be considered as a waiver of any subsequent breach of the same or any other provision.

11.3 If any provision of these Conditions is held by any competent authority to be invalid or unenforceable in whole or in part the validity of the other provisions of these Conditions and the remainder of the provision in question shall not be affected thereby.

11.4 The Contract shall be governed by the Laws of England and the parties agree to submit to the non-exclusive jurisdiction of the English Courts.

# CONTACT US

For more information on our lifting products, please visit [www.petersen-stainless.co.uk](http://www.petersen-stainless.co.uk), or contact the team on **+44 191 414 0156** or [sales@petersen-stainless.co.uk](mailto:sales@petersen-stainless.co.uk).



## Head Office

Blaydon upon Tyne  
UK

T: +44 191 414 0156  
E: [sales@petersen-stainless.co.uk](mailto:sales@petersen-stainless.co.uk)

## Northern & Eastern Europe

Gothenburg  
Sweden

T: +46 73 388 23 88  
E: [sales@petersen-stainless.se](mailto:sales@petersen-stainless.se)

## South East Asia and Australia

Kuala Lumpur  
Malaysia

T: +60 18 322 9178  
E: [sea@petersen-stainless.co.uk](mailto:sea@petersen-stainless.co.uk)

## North & South America

Annapolis, MD  
USA

T: +1 401 835 1850  
E: [sales@petersen-stainless.com](mailto:sales@petersen-stainless.com)