

# Original Instructions for the safe use of Petersen Hi-MOD PH Dee and Bow Shackles Pin Type A, AL, B.

Version 2010.2

In Accordance with the 2006/42/EC Machine Directive  
& The Supply of Machinery (Safety) Regulations 2008 (SI 2008/1597)

**The information in this leaflet should be passed to the user of the equipment**

## Introduction

All Petersen Hi-MOD PH Shackles have been manufactured and tested in accordance with the instructions and guidance detailed within 2006/42/EC Machine Directive and The Supply of Machinery (Safety) Regulations 2008 (SI 2008/1597).

Petersen PH shackles are manufactured from 17-4 stainless steel and are proof-tested to twice their Working Load Limit (WLL) using equipment calibrated to BS EN 10002-2 and NAMAS NIS 0424. The static test coefficient ratio is 2:1.

## Design & Application

All Petersen PH shackles have a specific design for a specific application. The Petersen PH shackle range is designed and manufactured for general lifting applications. **The Petersen PH Shackles are not to be used for lifting people or used on other equipment to lift people.**

## Manufacturer and Place of Manufacture

The Petersen PH Shackles are manufactured by Petersen Stainless Rigging Limited at their production facility located at Cowen Road, Blaydon on Tyne, Tyne & Wear, NE21 5TW, United Kingdom.

## Product Information & Description

Petersen PH shackles are made from PH 17/4, a martensitic precipitation/age hardening 17% chromium, 4% nickel stainless steel, offering high strength and hardness together with excellent corrosion resistance. PH shackles are heat treated to between condition H1025 and condition H1075 to achieve the optimum balance of mechanical properties and resistance to corrosion: in this state PH 17/4 closely approaches stainless types 302 and 304 for most corrosion agents.

Because of the critical dependence of the strength/corrosion characteristics on the heat treatment process it is imperative that no attempt is made to anneal Petersen PH shackles for whatever reason.

### ALWAYS:

- Store and handle shackles correctly.
- Inspect shackles before use and before placing into storage.
- Select the correct pattern of shackle and pin for the application.
- Allow for the full resultant imposed load.
- Fully tighten the pin.
- Ensure the load acts through the centre line of the shackle using spacers if necessary to meet this requirement.

### NEVER:

- Use shackles with bent pins or deformed bodies.
- Force, hammer or wedge shackles into position.
- Eccentrically load shackles.
- Replace the pin with a bolt.
- Fit pins in contact with moving parts which may loosen or unscrew them.
- Shock load shackles.
- Use the shackles to lift a person or people.
- Never load the shackles sideways – please refer to the “How to Load” diagrams.

A Technical file has been produced and is kept by the manufacturer in accordance with the instructions and guidance detailed within 2006/42/EC Machine Directive.

## Storing and Handling Shackles

Never return damaged shackles to storage. They should be dry, clean and protected from corrosion. Do not alter, modify or repair shackles and never replace missing pins, bolts etc., but refer such matters to a competent person. Never galvanise or subject to other plating processes without the approval of the manufacturer.

## Working Load Limit (WLL)

The Working Load Limit refers to static loading - care must be taken to ensure that any shock or dynamic loads do not exceed the WLL.

## Spreading of load

The load must not be concentrated over a small area e.g. by knife edges or small diameter steel ropes.

## Operating temperature

If the intended environment of the PH shackle involves elevated or depressed temperatures please refer to Petersen Technical Department for advice.

## Technical information - Analysis

A typical analysis of PH 17/4:-

Carbon	0.07% max
Manganese	1.00% max
Silicon	1.00% max
Phosphorus	0.04% max
Sulphur	0.03% max
Chromium	15.50 - 17.50%
Nickel	3.00 - 5.00%
Columbium & Tantalum	0.15 - 0.45%
Copper	3.00 - 5.00%
Iron	to 100%

## Mechanical properties - minima

Ultimate tensile strength  
10,900 kg/cm<sup>2</sup> (H1025) to 10,190kg/cm<sup>2</sup> (H1075)  
Yield strength (0.2%)  
10,190 kg/cm<sup>2</sup> (H1025) to 8,790kg/cm<sup>2</sup> (H1075)

## Mechanical properties - typical

Ultimate tensile strength  
11,810 kg/cm<sup>2</sup> (H1025) to 11,530kg/cm<sup>2</sup> (H1075)  
Yield strength (0.2%)  
11,390 kg/cm<sup>2</sup> (H1025) to 10,410kg/cm<sup>2</sup> (H1075).

## Assembly

The pin and shackle body will screw together easily and should be firmly fastened. Do not use any threading pastes or other such products which may attract or hold small pieces of dirt or metal.

Do not use the shackle if the pin does not screw fully into place. Please refer to the “How to Load” diagrams for a demonstration of correct assembly.

## Instructions for use

Shackles should be inspected before use to ensure that:

- all markings are legible;
- the threads of the pin and the body are undamaged;
- never use a safety type bolt/pin without using the split cotter pin;
- the body and the pin are not distorted or unduly worn;
- the body and pin are free from nicks, gouges, cracks and corrosion;
- shackles may not be heat treated as this may affect their working load limit;
- never modify, repair or reshape a shackle as this will affect the Working Load Limit.

# Original Instructions for the safe use of Petersen Hi-MOD PH Dee and Bow Shackles Pin Type A, AL, B.

Version 2010.2

In Accordance with the 2006/42/EC Machine Directive  
& The Supply of Machinery (Safety) Regulations 2008 (SI 2008/1597)

**The information in this leaflet should be passed to the user of the equipment**

## Inspection of shackle.

Before the shackle is first put into use it should be examined for signs of damage.

If it is known, or suspected, that the shackle has been subjected to an excess load or the shackle shows any sign of cracking, splitting or deformation it must be destroyed.

It is required that the shackles are regularly inspected and that the inspection should take place in accordance with the safety standards given in the country of use. This is required because the products in use may be affected by wear, misuse, overloading etc. with a consequence of deformation and alteration of the material structure. Inspection should take place at least every 6 months and even more frequently when the shackles are used in severe operating conditions.

Fig 1.

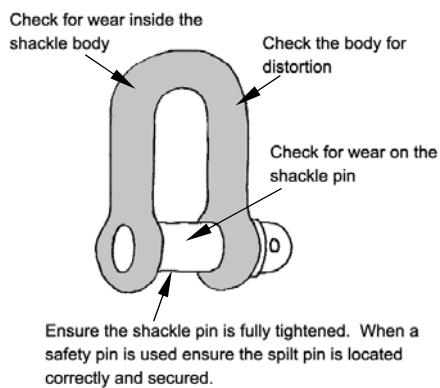

- For long term installations, safety pin shackles incorporating a cotter pin should be used. The pin should be secured from rotation or loosening.
- Shackles should not be dragged on an abrasive surface.
- Multiple slings in the body of the shackle shall not exceed 120 degree included angle.

## How to Load

Fig 2.

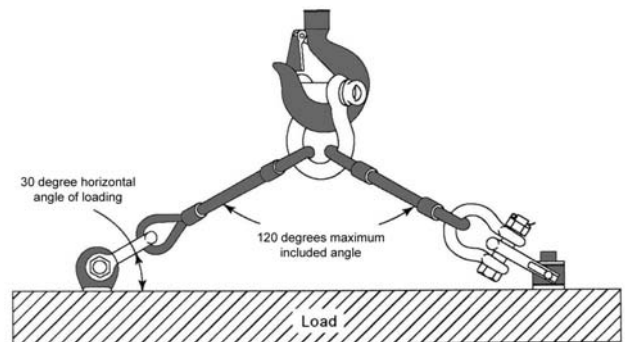

Horizontal Angle, Degrees	Stress Multiplier
90	1.000
60	1.155
45	1.414
30	2.000

## Product marking

For example WLL 2t PH A55 CE

WLL 2t Working Load Limit in tonnes  
PH material identification  
A55 test batch reference number  
CE Conformity code European mark certifying conformity with 2006/42/EC Machine Directive.



- Shackles should always be used in line with good rigging practice and as per the manufacturer's recommendations.
- Incorrect shackle use could result in a dangerous situation that could cause property damage, serious injury or death.

## Good Rigging Practices

- The screw pin must be fully engaged, with the head of the pin in contact with the shackle body.
- If a shackle is designed for a cotter pin, any replacement cotter pins must meet or exceed the original manufacturer's specification.
- Contact with sharp edges which could damage the shackle should be avoided.
- Shock loading should be avoided.
- The load applied to the shackle should be centered in the bow of the shackle to prevent side loading of the shackle.
- Multiple sling legs should not be applied to the shackle pin.
- If the shackle is to be side loaded, the rated load shall be reduced according to the recommendations of the manufacturer or qualified person (see fig 3).
- The screw pin shall not be rigged in a manner that would cause the pin to unscrew.

Fig 3.

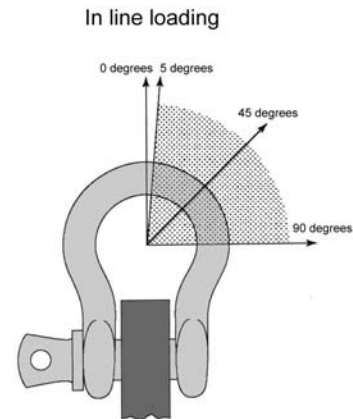

Side Loading Angle, degrees	% Rate Load Reduction
In-line (0) to 5	None
6 to 45	30%
46 to 90	50%
Over 90	Not recommended to load in this condition. Consult manufacturer or qualified person